

National Testing Agency

Question Paper Name :	B Tech 2nd Apr 2026 Shift 1
Subject Name :	B. Tech
Creation Date :	2026-04-02 14:02:41
Duration :	180
Total Marks :	300
Display Marks:	Yes

B. Tech

Group Number :	1
Group Id :	6911211
Group Maximum Duration :	0
Group Minimum Duration :	180
Show Attended Group? :	No
Edit Attended Group? :	No
Break time :	0
Group Marks :	300

Mathematics Section A

Section Id :	6911211
Section Number :	1
Section type :	Online
Mandatory or Optional :	Mandatory
Number of Questions :	20
Number of Questions to be attempted :	20
Section Marks :	80
Maximum Instruction Time :	0
Sub-Section Number :	1
Sub-Section Id :	6911211
Question Shuffling Allowed :	Yes
Is Section Default? :	No

Question Number : 1 Question Id : 6911211 Question Type : MCQ Option Shuffling : Yes Display Question Number : Yes Is Question Mandatory : No Single Line Question Option : No Option Orientation : Vertical

Let $\alpha, \alpha + 2, \alpha \in \mathbf{Z}$, be the roots of the quadratic equation

$$x(x + 2) + (x + 1)(x + 3) + (x + 2)(x + 4) + \dots + (x + n - 1)(x + n + 1) = 4n \text{ for some } n \in \mathbf{N}.$$

Then $n + \alpha$ is equal to :

Options :

6911211. 0

6911212. 1

6911213. 2

6911214. 3

Question Number : 2 Question Id : 6911212 Question Type : MCQ Option Shuffling : Yes Display Question Number : Yes Is Question Mandatory : No Single Line Question Option : No Option Orientation : Vertical

Let x and y be real numbers such that $50\left(\frac{2x}{1+3i} - \frac{y}{1-2i}\right) = 31 + 17i$, $i = \sqrt{-1}$. Then the value of $10(x - 3y)$ is :

Options :

6911215. 20

6911216. 31

6911217. 35

6911218. 75

Question Number : 3 Question Id : 6911213 Question Type : MCQ Option Shuffling : Yes Display Question Number : Yes Is Question Mandatory : No Single Line Question Option : No Option Orientation : Vertical

Let $\alpha, \beta \in \mathbb{R}$ be such that the system of linear equations

$$x + 2y + z = 5$$

$$2x + y + \alpha z = 5$$

$$8x + 4y + \beta z = 18$$

has no solution. Then $\frac{\beta}{\alpha}$ is equal to :

Options :

6911219. -4

69112110. 4

69112111. 8

69112112. -8

Question Number : 4 Question Id : 6911214 Question Type : MCQ Option Shuffling : Yes Display Question Number : Yes Is Question Mandatory : No Single Line Question Option : No Option Orientation : Vertical

Let $A = \begin{bmatrix} 1 & 2 \\ 1 & \alpha \end{bmatrix}$ and $B = \begin{bmatrix} 3 & 3 \\ \beta & 2 \end{bmatrix}$. If $A^2 - 4A + I = O$ and $B^2 - 5B - 6I = O$, then among the two statements :

$$(S1): [(B-A)(B+A)]^T = \begin{bmatrix} 13 & 15 \\ 7 & 10 \end{bmatrix}$$

and

$$(S2): \det(\text{adj}(A+B)) = -5,$$

Options :

69112113. only (S1) is correct

69112114. only (S2) is correct

69112115. both (S1) and (S2) are correct

69112116. both (S1) and (S2) are wrong

Question Number : 5 Question Id : 6911215 Question Type : MCQ Option Shuffling : Yes Display Question Number : Yes Is Question Mandatory : No Single Line Question Option : No Option Orientation : Vertical

Let A be the set of first 101 terms of an A.P., whose first term is 1 and the common difference is 5 and let B be the set of first 71 terms of an A.P., whose first term is 9 and the common difference is 7. Then the number of elements in $A \cap B$, which are divisible by 3, is :

Options :

69112117. 4

69112118. 5

69112119. 6

69112120. 7

Question Number : 6 Question Id : 6911216 Question Type : MCQ Option Shuffling : Yes Display Question Number : Yes Is Question Mandatory : No Single Line Question Option : No Option Orientation : Vertical

The number of seven-digit numbers, that can be formed by using the digits 1, 2, 3, 5 and 7 such that each digit is used at least once, is :

Options :

69112121. 15400

69112122. 17800

69112123. 16800

69112124. 29400

Question Number : 7 Question Id : 6911217 Question Type : MCQ Option Shuffling : Yes Display Question Number : Yes Is Question Mandatory : No Single Line Question Option : No Option Orientation : Vertical

The number of elements in the set $S = \left\{ (r, k) : k \in \mathbb{Z} \text{ and } {}^{36}C_{r+1} = \frac{6({}^{35}C_r)}{(k^2-3)} \right\}$, is :

Options :

69112125. 2

69112126. 4

69112127. 8

69112128. 16

Question Number : 8 Question Id : 6911218 Question Type : MCQ Option Shuffling : Yes Display Question Number : Yes Is Question Mandatory : No Single Line Question Option : No Option Orientation : Vertical

If the mean of the data

Class	5-10	10-15	15-20	20-25	25-30	30-35
Frequency	2	k	28	54	k+1	5

is 21, then k is one of the roots of the equation :

Options :

69112129. $2x^2 - 23x - 10 = 0$

69112130. $4x^2 - 35x + 24 = 0$

69112131. $2x^2 - 19x - 10 = 0$

69112132. $2x^2 - 35x + 98 = 0$

Question Number : 9 Question Id : 6911219 Question Type : MCQ Option Shuffling : Yes Display Question Number : Yes Is Question Mandatory : No Single Line Question Option : No Option Orientation : Vertical

Let the mid points of the sides of a triangle ABC be $\left(\frac{5}{2}, 7\right)$, $\left(\frac{5}{2}, 3\right)$ and $(4, 5)$. If its incentre is (h, k) , then $3h + k$ is equal to :

Options :

69112133. 11

69112134. 12

69112135. 13

69112136. 14

Question Number : 10 Question Id : 69112110 Question Type : MCQ Option Shuffling : Yes Display Question Number : Yes Is Question Mandatory : No Single Line Question Option : No Option Orientation : Vertical

Let an ellipse $\frac{x^2}{a^2} + \frac{y^2}{b^2} = 1$, $a < b$, pass through the point $(4, 3)$ and have eccentricity $\frac{\sqrt{5}}{3}$.

Then the length of its latus rectum is :

Options :

69112137. $\frac{4\sqrt{5}}{3}$

69112138. $2\sqrt{5}$

69112139. $\frac{7\sqrt{5}}{3}$

69112140. $\frac{8\sqrt{5}}{3}$

Question Number : 11 Question Id : 69112111 Question Type : MCQ Option Shuffling : Yes Display Question Number : Yes Is Question Mandatory : No Single Line Question Option : No Option Orientation : Vertical

If $\sin\left(\frac{\pi}{18}\right)\sin\left(\frac{5\pi}{18}\right)\sin\left(\frac{7\pi}{18}\right) = K$, then the value of $\sin\left(\frac{10K\pi}{3}\right)$ is :

Options :

69112141. $\frac{\sqrt{3} + 1}{2\sqrt{2}}$

69112142. $\frac{\sqrt{3} - 1}{\sqrt{2}}$

69112143. $\frac{\sqrt{3}}{2}$

69112144. $\frac{1}{2}$

Question Number : 12 Question Id : 69112112 Question Type : MCQ Option Shuffling : Yes Display Question Number : Yes Is Question Mandatory : No Single Line Question Option : No Option Orientation : Vertical

Let $S = \{x \in [-\pi, \pi] : \sin x (\sin x + \cos x) = a, a \in \mathbb{Z}\}$. Then $n(S)$ is equal to :

Options :

69112145. 3

69112146. 6

69112147. 7

69112148. 9

Question Number : 13 Question Id : 69112113 Question Type : MCQ Option Shuffling : Yes Display Question Number : Yes Is Question Mandatory : No Single Line Question Option : No Option Orientation : Vertical

If the point of intersection of the lines $\frac{x+1}{3} = \frac{y+a}{5} = \frac{z+b+1}{7}$ and $\frac{x-2}{1} = \frac{y-b}{4} = \frac{z-2a}{7}$ lies on xy -plane, then the value of $a + b$ is :

Options :

69112149. 2

69112150. 5

69112151. 7

69112152. 9

Question Number : 14 Question Id : 69112114 Question Type : MCQ Option Shuffling : Yes Display Question Number : Yes Is Question Mandatory : No Single Line Question Option : No Option Orientation : Vertical

If \vec{a} and \vec{b} are two vectors such that $|\vec{a}| = 2$ and $|\vec{b}| = 3$, then the maximum value of $3\left|\left(3\vec{a} + 2\vec{b}\right)\right| + 4\left|\left(3\vec{a} - 2\vec{b}\right)\right|$ is :

Options :

69112153. 30

69112154. 36

69112155. 60

69112156. 72

Question Number : 15 Question Id : 69112115 Question Type : MCQ Option Shuffling : Yes Display Question Number : Yes Is Question Mandatory : No Single Line Question Option : No Option Orientation : Vertical

Let a line L passing through the point $(1, 1, 1)$ be perpendicular to both the vectors $2\hat{i} + 2\hat{j} + \hat{k}$ and $\hat{i} + 2\hat{j} + 2\hat{k}$. If P(a, b, c) is the foot of perpendicular from the origin on the line L, then the value of $34(a + b + c)$ is :

Options :

69112157. 50

69112158. 80

69112159. 100

69112160. 120

Question Number : 16 Question Id : 69112116 Question Type : MCQ Option Shuffling : Yes Display Question Number : Yes Is Question Mandatory : No Single Line Question Option : No Option Orientation : Vertical

If $\lim_{x \rightarrow 2} \frac{\sin(x^3 - 5x^2 + ax + b)}{(\sqrt{x-1} - 1) \log_e(x-1)} = m$, then $a + b + m$ is equal to :

Options :

69112161. 5

69112162. 6

69112163. 8

69112164. 10

Question Number : 17 Question Id : 69112117 Question Type : MCQ Option Shuffling : Yes Display Question Number : Yes Is Question Mandatory : No Single Line Question Option : No Option Orientation : Vertical

If the curve $y = f(x)$ passes through the point $(1, e)$ and satisfies the differential equation $dy = y(2 + \log_e x) dx$, $x > 0$, then $f(e)$ is equal to :

Options :

69112165. e^e 69112166. e^{e^2} 69112167. e^{2e} 69112168. e^{2^e}

Question Number : 18 Question Id : 69112118 Question Type : MCQ Option Shuffling : Yes Display Question Number : Yes Is Question Mandatory : No Single Line Question Option : No Option Orientation : Vertical

The number of critical points of the function $f(x) = \begin{cases} \left| \frac{\sin x}{x} \right|, & x \neq 0 \\ 1, & x = 0 \end{cases}$ in the interval $(-2\pi, 2\pi)$ is

equal to :

Options :

69112169. 1

69112170. 3

69112171. 5

69112172. 7

Question Number : 19 Question Id : 69112119 Question Type : MCQ Option Shuffling : Yes Display Question Number : Yes Is Question Mandatory : No Single Line Question Option : No Option Orientation : Vertical

Let $[\cdot]$ denote the greatest integer function. Then the value of $\int_0^3 \left(\frac{e^x + e^{-x}}{[x]!} \right) dx$ is :

Options :

69112173. $e^2 + e^3 - \frac{1}{e^2} - \frac{1}{e^3}$

69112174. $\frac{1}{2} \left(e^2 + e^3 - \frac{1}{e^2} - \frac{1}{e^3} \right)$

69112175. $e^2 + e^3 - \frac{1}{2e^2} - \frac{1}{2e^3}$

69112176. $\frac{1}{2} (e^2 + e^3) - \frac{1}{e^2} - \frac{1}{e^3}$

Question Number : 20 Question Id : 69112120 Question Type : MCQ Option Shuffling : Yes Display Question Number : Yes Is Question Mandatory : No Single Line Question Option : No Option Orientation : Vertical

Let $y = y(x)$ be the solution curve of the differential equation

$$(1 + \sin x) \frac{dy}{dx} + (y+1) \cos x = 0, y(0) = 0. \text{ If the curve } y = y(x) \text{ passes through the point } \left(\alpha, \frac{-1}{2} \right),$$

then a value of α is :

Options :

69112177. $\frac{\pi}{6}$

69112178. $\frac{\pi}{4}$

69112179. $\frac{\pi}{3}$

69112180. $\frac{\pi}{2}$

Mathematics Section B

Section Id : 6911212
 Section Number : 2
 Section type : Online
 Mandatory or Optional : Mandatory

Number of Questions :	5
Number of Questions to be attempted :	5
Section Marks :	20
Maximum Instruction Time :	0
Sub-Section Number :	1
Sub-Section Id :	6911212
Question Shuffling Allowed :	Yes
Is Section Default? :	No

Question Number : 21 Question Id : 69112121 Question Type : SA Display Question Number : Yes Keyboard Layout : Inscript

If the domain of the function $f(x) = \sqrt{\log_{(0.6)} \left(\left| \frac{2x-5}{x^2-4} \right| \right)}$ is $(-\infty, a] \cup \{b\} \cup [c, d) \cup (e, \infty)$, then the value of $a + b + c + d + e$ is _____.

Response Type : Numeric

Evaluation Required For SA : Yes

Show Word Count : Yes

Answers Type : Equal

Text Areas : PlainText

Possible Answers :

1

Question Number : 22 Question Id : 69112122 Question Type : SA Display Question Number : Yes Keyboard Layout : Inscript

If $\sum_{k=1}^n a_k = 6n^3$, then $\sum_{k=1}^6 \left(\frac{a_{k+1} - a_k}{36} \right)^2$ is equal to _____.

Response Type : Numeric

Evaluation Required For SA : Yes

Show Word Count : Yes

Answers Type : Equal

Text Areas : PlainText

Possible Answers :

1

Question Number : 23 Question Id : 69112123 Question Type : SA Display Question Number : Yes Keyboard Layout : Inscript

Let $a, b, c \in \{1, 2, 3, 4\}$. If the probability, that $ax^2 + 2\sqrt{2}bx + c > 0$ for all $x \in \mathbf{R}$, is $\frac{m}{n}$, $\gcd(m, n) = 1$, then $m + n$ is equal to _____.

Response Type : Numeric

Evaluation Required For SA : Yes

Show Word Count : Yes

Answers Type : Equal

Text Areas : PlainText

Possible Answers :

1

Question Number : 24 Question Id : 69112124 Question Type : SA Display Question Number : Yes Keyboard Layout : Inscript

Let a circle C have its centre in the first quadrant, intersect the coordinate axes at exactly three points and cut off equal intercepts from the coordinate axes. If the length of the chord of C on the line $x + y = 1$ is $\sqrt{14}$, then the square of the radius of C is _____.

Response Type : Numeric

Evaluation Required For SA : Yes

Show Word Count : Yes

Answers Type : Equal

Text Areas : PlainText

Possible Answers :

1

Question Number : 25 Question Id : 69112125 Question Type : SA Display Question Number : Yes Keyboard Layout : Inscript

If $\alpha = \int_0^{2\sqrt{3}} \log_2(x^2+4) dx + \int_2^4 \sqrt{2^x-4} dx$, then α^2 is equal to _____.

Response Type : Numeric

Evaluation Required For SA : Yes

Show Word Count : Yes

Answers Type : Equal

Text Areas : PlainText

Possible Answers :

1

Physics Section A

Section Id :	6911213
Section Number :	3
Section type :	Online
Mandatory or Optional :	Mandatory
Number of Questions :	20
Number of Questions to be attempted :	20
Section Marks :	80
Maximum Instruction Time :	0
Sub-Section Number :	1
Sub-Section Id :	6911213
Question Shuffling Allowed :	Yes
Is Section Default? :	No

Question Number : 26 Question Id : 69112126 Question Type : MCQ Option Shuffling : Yes Display Question Number : Yes Is Question Mandatory : No Single Line Question Option : No Option Orientation : Vertical

The dimensional formula of $\frac{1}{2} \epsilon_0 E^2$ (ϵ_0 = permittivity of vacuum and E = electric field) is $M^a L^b T^c$.

The value of $2a - b + c =$ _____.

Options :

69112186. 0

69112187. 1

69112188. -1

69112189. 2

Question Number : 27 Question Id : 69112127 Question Type : MCQ Option Shuffling : Yes Display Question Number : Yes Is Question Mandatory : No Single Line Question Option : No Option Orientation : Vertical

The diameter of a wire measured by a screw gauge of least count 0.001 cm is 0.08 cm. The length measured by a scale of least count 0.1 cm is 150 cm. When a weight of 100 N is applied to the wire, the extension in length is 0.5 cm, measured by a micrometer of least count 0.001 cm. The error in the measured Young's modulus is $\alpha \times 10^9$ N/m². The value of α is _____.
(Ignore the contribution of the load to Young's modulus error calculation)

Options :

69112190. 1.3

69112191. 1.65

69112192. 0.13

69112193. 0.25

Question Number : 28 Question Id : 69112128 Question Type : MCQ Option Shuffling : Yes Display Question Number : Yes Is Question Mandatory : No Single Line Question Option : No Option Orientation : Vertical

The velocity of a particle is given as $\vec{v} = -x\hat{i} + 2y\hat{j} - z\hat{k}$ m/s. The magnitude of acceleration at point (1, 2, 4) is _____ m/s².

Options :

69112194. $\sqrt{6}$

69112195. 9

69112196. $\sqrt{33}$

69112197. 0

Question Number : 29 Question Id : 69112129 Question Type : MCQ Option Shuffling : Yes Display Question Number : Yes Is Question Mandatory : No Single Line Question Option : No Option Orientation : Vertical

The position of an object having mass 0.1 kg as a function of time t is given as $\vec{r} = \left(10t^2\hat{i} + 5t^3\hat{j}\right)$ m. At $t=1$ s, which of the following statements are correct ?

A. The linear momentum $\vec{p} = \left(2\hat{i} + 1.5\hat{j}\right)$ kg·m/s.

B. The force acting on the object $\vec{F} = \left(2\hat{i} + 3\hat{j}\right)$ N.

C. The angular momentum of the object about its origin $\vec{L} = 15\hat{k}$ J s.

D. The torque acting on the object about its origin $\vec{\tau} = 20\hat{k}$ N m.

Choose the correct answer from the options given below :

Options :

69112198. A, B and C only

69112199. B, C and D only

691121100. A, C and D only

691121101. A, B and D only

Question Number : 30 Question Id : 69112130 Question Type : MCQ Option Shuffling : Yes Display Question Number : Yes Is Question Mandatory : No Single Line Question Option : No Option Orientation : Vertical

A planet (P_1) is moving around the star of mass $2M$ in the orbit of radius R . Another planet (P_2) is moving around another star of mass $4M$ in a orbit of radius $2R$. Ratio of time periods of revolution of P_2 and P_1 is _____.

Options :

691121102. $\frac{1}{2}$

691121103. 2

691121104. 4

691121105. $\frac{1}{4}$

Question Number : 31 Question Id : 69112131 Question Type : MCQ Option Shuffling : Yes Display Question Number : Yes Is Question Mandatory : No Single Line Question Option : No Option Orientation : Vertical

A particle is rotating in a circular path and at any instant its motion can be described as

$\theta = \frac{5t^4}{40} - \frac{t^3}{3}$. The angular acceleration of the particle after 10 seconds is _____ rad/s².

Options :

691121106. 150

691121107. 120

691121108. 130

691121109. 170

Question Number : 32 Question Id : 69112132 Question Type : MCQ Option Shuffling : Yes Display Question Number : Yes Is Question Mandatory : No Single Line Question Option : No Option Orientation : Vertical

A parallel plate air capacitor has a capacitance C . When it is half filled as show in figure with a dielectric constant $K=5$, the percentage increase in the capacitance is _____.

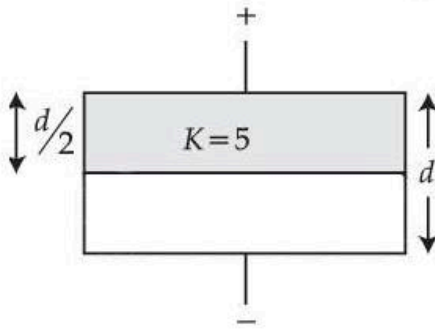

Options :

691121110. 33.34

691121111. 66.67

691121112. 200

691121113. 400

Question Number : 33 Question Id : 69112133 Question Type : MCQ Option Shuffling : Yes Display Question Number : Yes Is Question Mandatory : No Single Line Question Option : No Option Orientation : Vertical

Heat is supplied to a diatomic gas at constant pressure. Then the ratio of $\Delta Q : \Delta U : \Delta W$ is _____.

Options :

691121114. 2 : 3 : 5

691121115. 5 : 3 : 2

691121116. 2 : 5 : 7

691121117. 7 : 5 : 2

Question Number : 34 Question Id : 69112134 Question Type : MCQ Option Shuffling : Yes Display Question Number : Yes Is Question Mandatory : No Single Line Question Option : No Option Orientation : Vertical

Two charged conducting spheres S_1 and S_2 of radii 8 cm and 18 cm are connected to each other by a wire. After equilibrium is established, the ratio of electric fields on S_1 and S_2 spheres are E_{S_1} and

E_{S_2} respectively. The value of $\frac{E_{S_1}}{E_{S_2}}$ is _____.

Options :

691121118. $\frac{3}{2}$

691121119. $\frac{2}{3}$

691121120. $\frac{4}{9}$

691121121. $\frac{9}{4}$

Question Number : 35 Question Id : 69112135 Question Type : MCQ Option Shuffling : Yes Display Question Number : Yes Is Question Mandatory : No Single Line Question Option : No Option Orientation : Vertical

The equation of a plane progressive wave is given by $y = 5 \cos \pi \left(200 t - \frac{x}{150} \right)$ where x and y are in cm and t is in second. The velocity of the wave is _____ m/s.

Options :

691121122. 120

691121123. 150

691121124. 200

691121125. 300

Question Number : 36 Question Id : 69112136 Question Type : MCQ Option Shuffling : Yes Display Question Number : Yes Is Question Mandatory : No Single Line Question Option : No Option Orientation : Vertical

Two short electric dipoles A and B having dipole moment p_1 and p_2 respectively are placed with their axis mutually perpendicular as shown in the figure. The resultant electric field at a point x is making an angle of 60° with the line joining points O and x . The ratio of the dipole moments p_2/p_1 is _____.



Options :

691121126. $\frac{\sqrt{3}}{2}$

691121127. $2\sqrt{3}$

691121128. $\frac{1}{\sqrt{3}}$

691121129. $\sqrt{3}$

Question Number : 37 Question Id : 69112137 Question Type : MCQ Option Shuffling : Yes Display Question Number : Yes Is Question Mandatory : No Single Line Question Option : No Option Orientation : Vertical

For the given circuit (shown in part (A)) the time dependent input voltage $v_{in}(t)$ and corresponding output $v_o(t)$ are shown in part (B) and part (C), respectively. Identify the components that are used in the circuit between points X and Y.

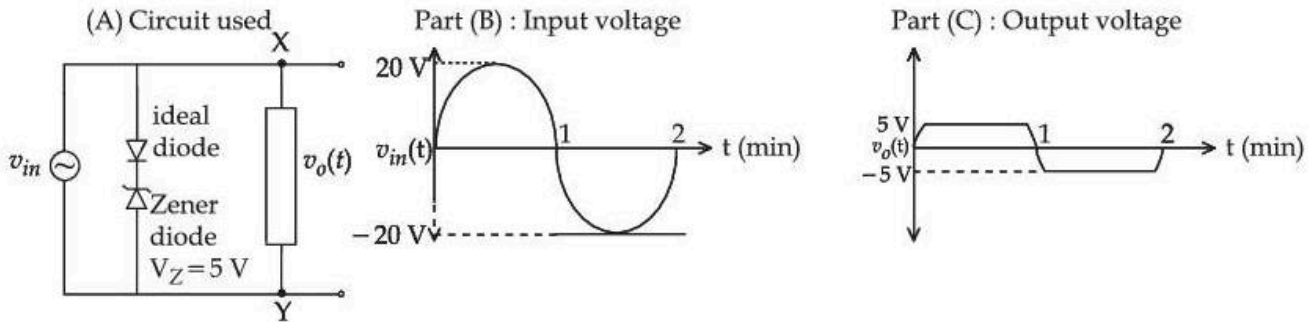

Options :

691121130.

691121131.

691121132.

691121133.

Question Number : 38 Question Id : 69112138 Question Type : MCQ Option Shuffling : Yes Display Question Number : Yes Is Question Mandatory : No Single Line Question Option : No Option Orientation : Vertical

When a coil is placed in a time dependent magnetic field the power dissipated in it is P . The number of turns, area of the coil and radius of the coil wire are N, A and r respectively. For a second coils number of turns, area of the coil and radius of the coil wire are $2N, 2A$ and $3r$ respectively. When the first coil is replaced with second coil the power dissipated in it is $\sqrt{2} \alpha P$. The value of α is _____.

Options :

691121134. 36

691121135. $128 \sqrt{2}$

691121136. 16

691121137. 64

Question Number : 39 Question Id : 69112139 Question Type : MCQ Option Shuffling : Yes Display Question Number : Yes Is Question Mandatory : No Single Line Question Option : No Option Orientation : Vertical

Two identical long current carrying wires are bent into the shapes shown in the following figures. If the magnitude of magnetic fields at the centres P and Q of a semicircular arc are B_1 and B_2

respectively, then the ratio $\frac{B_1}{B_2}$ is _____.

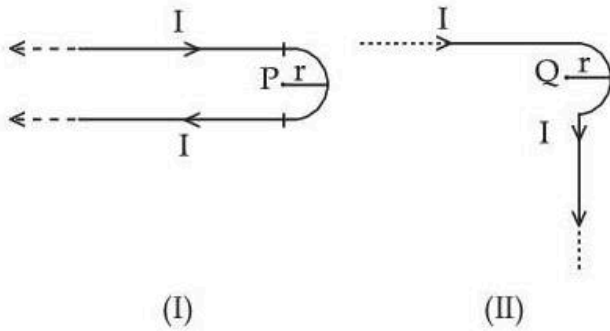

Options :

691121138. $\frac{2 + \pi}{1 + \pi}$

691121139. $\frac{1 + \pi}{1 - \pi}$

691121140. $\frac{2 + \pi}{1 - \pi}$

691121141. $\frac{1 + \pi}{2 - \pi}$

Question Number : 40 Question Id : 69112140 Question Type : MCQ Option Shuffling : Yes Display Question Number : Yes Is Question Mandatory : No Single Line Question Option : No Option Orientation : Vertical

For a thin symmetric prism made of glass (refractive index 1.5), the ratio of incident angle and minimum deviation will be _____.

Options :

691121142. 3 : 4

691121143. 3 : 2

691121144. 2 : 1

691121145. 1 : 2

Question Number : 41 Question Id : 69112141 Question Type : MCQ Option Shuffling : Yes Display Question Number : Yes Is Question Mandatory : No Single Line Question Option : No Option Orientation : Vertical

Refer the figure given below. μ_1 and μ_2 are refractive indices of air and lens material. The height of image will be _____ cm.

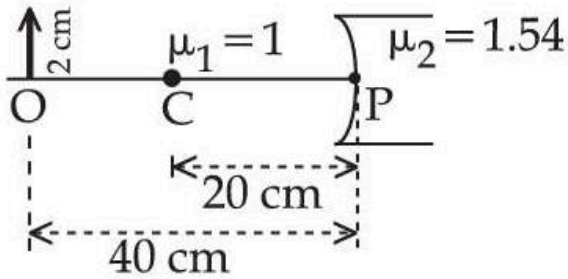

Options :

- 691121146. 1
- 691121147. 0.5
- 691121148. 1.2
- 691121149. 0.25

Question Number : 42 Question Id : 69112142 Question Type : MCQ Option Shuffling : Yes Display Question Number : Yes Is Question Mandatory : No Single Line Question Option : No Option Orientation : Vertical

For a certain metal, when monochromatic light of wavelength λ is incident, the stopping potential for photoelectrons is $3V_0$. When the same metal is illuminated by light of wavelength 2λ , then the stopping potential becomes V_0 . The threshold wavelength for photoelectric emission for the given metal is $\alpha\lambda$. The value of α is _____.

Options :

- 691121150. 1
- 691121151. 4
- 691121152. 2
- 691121153. 3

Question Number : 43 Question Id : 69112143 Question Type : MCQ Option Shuffling : Yes Display Question Number : Yes Is Question Mandatory : No Single Line Question Option : No Option Orientation : Vertical

An electromagnetic wave travelling in x -direction is described by field equation $E_y = 300 \sin \omega \left(t - \frac{x}{c} \right)$. If the electron is restricted to move in y -direction only with speed of 1.5×10^6 m/s then ratio of maximum electric and magnetic forces acting on the electron is _____.

Options :

- 691121154. 200

691121155. 150

691121156. 400

691121157. 300

Question Number : 44 Question Id : 69112144 Question Type : MCQ Option Shuffling : Yes Display Question Number : Yes Is Question Mandatory : No Single Line Question Option : No Option Orientation : Vertical

Angular momentum of an electron in a hydrogen atom is $\frac{3h}{\pi}$, then the energy of the electron is _____ eV.

Options :

691121158. - 1.51

691121159. - 0.85

691121160. - 0.38

691121161. - 0.28

Question Number : 45 Question Id : 69112145 Question Type : MCQ Option Shuffling : Yes Display Question Number : Yes Is Question Mandatory : No Single Line Question Option : No Option Orientation : Vertical

A liquid drop of diameter 2 mm breaks into 512 droplets. The change in surface energy is $\alpha \times 10^{-6}$ J. The value of α is _____. (Take surface tension of liquid = 0.08 N/m)

Options :

691121162. 10

691121163. 7

691121164. 8

691121165. 11

Physics Section B

Section Id :	6911214
Section Number :	4
Section type :	Online
Mandatory or Optional :	Mandatory
Number of Questions :	5
Number of Questions to be attempted :	5
Section Marks :	20
Maximum Instruction Time :	0
Sub-Section Number :	1
Sub-Section Id :	6911214
Question Shuffling Allowed :	Yes

Is Section Default? :

No

Question Number : 46 Question Id : 69112146 Question Type : SA Display Question Number : Yes Keyboard Layout : Inscript

In single slit diffraction pattern, the wavelength of light used is 628 nm and slit width is 0.2 mm, the angular width of central maximum is $\alpha \times 10^{-2}$ degrees. The value of α is _____.

Response Type : Numeric

Evaluation Required For SA : Yes

Show Word Count : Yes

Answers Type : Equal

Text Areas : PlainText

Possible Answers :

1

Question Number : 47 Question Id : 69112147 Question Type : SA Display Question Number : Yes Keyboard Layout : Inscript

A vessel contains 0.15 m^3 of a gas at pressure 8 bar and temperature 140°C with $c_p = 3R$ and $c_v = 2R$. It is expanded adiabatically till pressure falls to 1 bar. The work done during this process is _____ k J. (R is gas constant)

Response Type : Numeric

Evaluation Required For SA : Yes

Show Word Count : Yes

Answers Type : Equal

Text Areas : PlainText

Possible Answers :

1

Question Number : 48 Question Id : 69112148 Question Type : SA Display Question Number : Yes Keyboard Layout : Inscript

$1 \mu\text{C}$ charge moving with velocity $\vec{v} = (\hat{i} - 2\hat{j} + 3\hat{k}) \text{ m/s}$ in the region of magnetic field

$\vec{B} = (2\hat{i} + 3\hat{j} - 5\hat{k}) \text{ T}$. The magnitude of force acting on it is $\sqrt{\alpha} \times 10^{-6} \text{ N}$. The value of α is _____.

Response Type : Numeric

Evaluation Required For SA : Yes

Show Word Count : Yes

Answers Type : Equal

Text Areas : PlainText

Possible Answers :

1

Question Number : 49 Question Id : 69112149 Question Type : SA Display Question Number : Yes Keyboard Layout : Inscript

A uniform wire of length l of weight w is suspended from the roof with a weight of W at the other end. The stress in the wire at $\frac{l}{3}$ distance from the top is $\left(\frac{W}{A} + \frac{2}{\gamma} \frac{w}{A}\right)$, where, A is the cross sectional area of the wire. The value of γ is _____.

Response Type : Numeric

Evaluation Required For SA : Yes

Show Word Count : Yes

Answers Type : Equal

Text Areas : PlainText

Possible Answers :

1

Question Number : 50 Question Id : 69112150 Question Type : SA Display Question Number : Yes Keyboard Layout : Inscript

A tub is filled with water and a wooden cube $10\text{ cm} \times 10\text{ cm} \times 10\text{ cm}$ is placed in the water. The wooden cube is found to float on the water with a part of it submerged in water. When a metal coin is placed on the wooden cube, the submerged part is increased by 3.87 cm. The mass of the metal coin is _____ gram.

(Take water density as 1 g/cm^3 and density of wood as 0.4 g/cm^3)

Response Type : Numeric

Evaluation Required For SA : Yes

Show Word Count : Yes

Answers Type : Equal

Text Areas : PlainText

Possible Answers :

1

Chemistry Section A

Section Id :	6911215
Section Number :	5
Section type :	Online
Mandatory or Optional :	Mandatory
Number of Questions :	20
Number of Questions to be attempted :	20
Section Marks :	80
Maximum Instruction Time :	0
Sub-Section Number :	1
Sub-Section Id :	6911215
Question Shuffling Allowed :	Yes
Is Section Default? :	No

Question Number : 51 Question Id : 69112151 Question Type : MCQ Option Shuffling : Yes Display Question Number : Yes Is Question Mandatory : No Single Line Question Option : No Option Orientation : Vertical

The mass of iron converted into Fe_3O_4 by the action of 18 g of steam is :

(Given : Molar mass of H, O and Fe are 1, 16 and 56 g mol^{-1} respectively)

Assume iron is present in excess :

Options :

691121171. 2.1 g

691121172. 4.2 g

691121173. 21 g

691121174. 42 g

Question Number : 52 Question Id : 69112152 Question Type : MCQ Option Shuffling : Yes Display Question Number : Yes Is Question Mandatory : No Single Line Question Option : No Option Orientation : Vertical

What is the energy (in J atom⁻¹) required for the following process ?

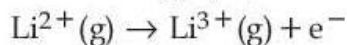

(Take the ionization energy for the H atom in the ground state as 2.18×10^{-18} J atom⁻¹)

Options :

691121175. 8.72×10^{-18}

691121176. 1.962×10^{-18}

691121177. 1.962×10^{-17}

691121178. 6.54×10^{-17}

Question Number : 53 Question Id : 69112153 Question Type : MCQ Option Shuffling : Yes Display Question Number : Yes Is Question Mandatory : No Single Line Question Option : No Option Orientation : Vertical

Given below are two statements :

Statement (I) : The correct sequence of bond lengths in the following species is :

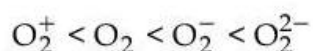

Statement (II) : The correct sequence of number of unpaired electrons in the following species is :

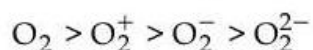

In the light of the above statements, choose the **correct answer** from the options given below :

Options :

691121179. Both **Statement I** and **Statement II** are true

691121180. Both **Statement I** and **Statement II** are false

691121181. **Statement I** is true but **Statement II** is false

691121182. **Statement I** is false but **Statement II** is true

Question Number : 54 Question Id : 69112154 Question Type : MCQ Option Shuffling : Yes Display Question Number : Yes Is Question Mandatory : No Single Line Question Option : No Option Orientation : Vertical

Consider the following data.

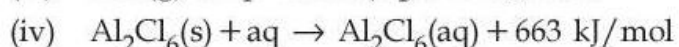
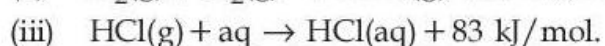
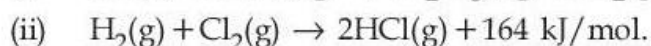
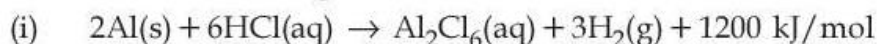

The enthalpy of formation of anhydrous solid Al_2Cl_6 is :

Options :

691121183. -648 kJ mol^{-1}

691121184. $-1350 \text{ kJ mol}^{-1}$

691121185. $-2002 \text{ kJ mol}^{-1}$

691121186. $-1527 \text{ kJ mol}^{-1}$

Question Number : 55 Question Id : 69112155 Question Type : MCQ Option Shuffling : Yes Display Question Number : Yes Is Question Mandatory : No Single Line Question Option : No Option Orientation : Vertical

19.5 g of fluoro acetic acid (molar mass = 78 g mol^{-1}) is dissolved in 500 g of water at 298 K. The depression in the freezing point of water was 1°C . What is K_a of fluoro acetic acid ? (For water, $K_f = 1.86 \text{ K kg mol}^{-1}$). Assume molarity and molality to have same values.

Options :

691121187. 10^{-6}

691121188. 4×10^{-4}

691121189. 3×10^{-5}

691121190. 3×10^{-3}

Question Number : 56 Question Id : 69112156 Question Type : MCQ Option Shuffling : Yes Display Question Number : Yes Is Question Mandatory : No Single Line Question Option : No Option Orientation : Vertical

The solubility product constants of Ag_2CrO_4 and AgBr are $32x$ and $4y$ respectively at 298 K.

The value of $\left(\frac{\text{molarity of } \text{Ag}_2\text{CrO}_4}{\text{molarity of } \text{AgBr}} \right)$ can be expressed as :

Options :

691121191. $\frac{2\sqrt[3]{x}}{y}$

691121192. $2\sqrt{\frac{x}{y}}$

691121193. $\sqrt{\frac{x}{y}}$

691121194. $\frac{\sqrt[3]{x}}{\sqrt{y}}$

Question Number : 57 Question Id : 69112157 Question Type : MCQ Option Shuffling : Yes Display Question Number : Yes Is Question Mandatory : No Single Line Question Option : No Option Orientation : Vertical

An electrochemical cell is constructed using half cells in the direction of spontaneous change

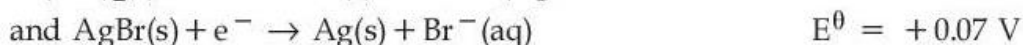
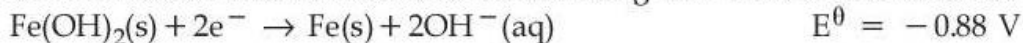

Which of the following option is correct ?

Options :

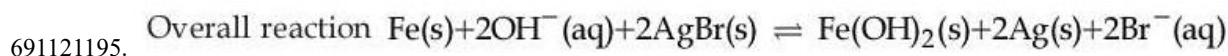

691121196. $E_{\text{cell}}^\theta = -0.95 \text{ V}$

691121197. Fe is reduced in the electrochemical cell

691121198. E_{cell}^θ is an extensive property

Question Number : 58 Question Id : 69112158 Question Type : MCQ Option Shuffling : Yes Display Question Number : Yes Is Question Mandatory : No Single Line Question Option : No Option Orientation : Vertical

$t_{100\%}$ is the time required for the 100% completion of the reaction while $t_{1/2}$ is the time required for 50% of the reaction to be completed. Which of the following option correctly represents the relation between $t_{100\%}$ and $t_{1/2}$ for zero and first order reactions respectively ?

Options :

691121199. $t_{100\%} = (t_{1/2})^2$ and $t_{100\%} = (t_{1/2})^{-\infty}$

691121200. $t_{100\%} = 2t_{1/2}$ and $t_{100\%} = (t_{1/2})^\infty$

691121201. $t_{100\%} = 2t_{1/2}$ and $t_{100\%} = (2t_{1/2})^2$

691121202. $t_{100\%} = (t_{1/2})^\infty$ and $t_{100\%} = 2t_{1/2}$

Question Number : 59 Question Id : 69112159 Question Type : MCQ Option Shuffling : Yes Display Question Number : Yes Is Question Mandatory : No Single Line Question Option : No Option Orientation : Vertical

Given below are two statements :

Statement (I) : The first ionisation enthalpy of the elements Na, Mg, Cl and Ar follows the order $\text{Na} > \text{Mg} > \text{Cl} > \text{Ar}$.

Statement (II) : Among Ca, Al, Fe and B, the third ionisation enthalpy is very high for Ca.

In the light of the above statements, choose the correct answer from the options given below :

Options :

691121203. Both **Statement I** and **Statement II** are true

691121204. Both **Statement I** and **Statement II** are false

691121205. **Statement I** is true but **Statement II** is false

691121206. **Statement I** is false but **Statement II** is true

Question Number : 60 Question Id : 69112160 Question Type : MCQ Option Shuffling : Yes Display Question Number : Yes Is Question Mandatory : No Single Line Question Option : No Option Orientation : Vertical

Given below are two statements :

Statement (I) : Oxidising power of halogens decreases in the order $F_2 > Cl_2 > Br_2 > I_2$, which is the basis of "Layer test".

Statement (II) : "Layer test" to identify Br_2 and I_2 in aqueous solution involves the oxidation of bromide or iodide into Br_2 or I_2 respectively with Cl_2 , which is a type of displacement redox reaction.

In the light of the above statements, choose the **correct answer** from the options given below :

Options :

691121207. Both **Statement I** and **Statement II** are true

691121208. Both **Statement I** and **Statement II** are false

691121209. **Statement I** is true but **Statement II** is false

691121210. **Statement I** is false but **Statement II** is true

Question Number : 61 Question Id : 69112161 Question Type : MCQ Option Shuffling : Yes Display Question Number : Yes Is Question Mandatory : No Single Line Question Option : No Option Orientation : Vertical

Which of the following sets includes all the species that will change the orange colour of $K_2Cr_2O_7$ in acidic medium ?

Options :

691121211. $Fe^{2+}, Sn^{2+}, I^-, S^{2-}$

691121212. $S^{2-}, Fe^{3+}, I^-, C_2O_4^{2-}$

691121213. $Fe^{2+}, NO_2^-, SO_2, Sn^{4+}$

691121214. $Fe^{3+}, SO_4^{2-}, S^{2-}, Sn^{4+}$

Question Number : 62 Question Id : 69112162 Question Type : MCQ Option Shuffling : Yes Display Question Number : Yes Is Question Mandatory : No Single Line Question Option : No Option Orientation : Vertical

Match List - I with List - II.

List - I	List - II
Chromium (III) Complexes (en = ethylene diamine)	$\Delta_0(\text{cm}^{-1})$
A. $[\text{Cr}(\text{CN})_6]^{3-}$	I. 15,060
B. $[\text{CrF}_6]^{3-}$	II. 17,400
C. $[\text{Cr}(\text{H}_2\text{O})_6]^{3+}$	III. 22,300
D. $[\text{Cr}(\text{en})_3]^{3+}$	IV. 26,600

Choose the **correct** answer from the options given below :

Options :

691121215. A-I, B-II, C-III, D-IV

691121216. A-II, B-III, C-IV, D-I

691121217. A-III, B-IV, C-I, D-II

691121218. A-IV, B-I, C-II, D-III

Question Number : 63 Question Id : 69112163 Question Type : MCQ Option Shuffling : Yes Display Question Number : Yes Is Question Mandatory : No Single Line Question Option : No Option Orientation : Vertical

Given below are two statements :

Statement (I) : 1,2,3-Trihydroxypropane can be separated from water by simple distillation.

Statement (II) : An azeotropic mixture cannot be separated by fractional distillation.

In the light of the above statements, choose the **correct** answer from the options given below :

Options :

691121219. Both **Statement I** and **Statement II** are true

691121220. Both **Statement I** and **Statement II** are false

691121221. **Statement I** is true but **Statement II** is false

691121222. **Statement I** is false but **Statement II** is true

Question Number : 64 Question Id : 69112164 Question Type : MCQ Option Shuffling : Yes Display Question Number : Yes Is Question Mandatory : No Single Line Question Option : No Option Orientation : Vertical

Given below are two statements :

Statement (I) : Benzyl chloride reacts faster in $\text{S}_{\text{N}}1$ mechanism than ethyl chloride.

Statement (II) : Ethyl carbocation intermediate is less stabilized by hyperconjugation than benzyl carbocation by resonance.

In the light of the above statements, choose the **correct** answer from the options given below :

Options :

691121223. Both **Statement I** and **Statement II** are true

691121224. Both **Statement I** and **Statement II** are false

691121225. **Statement I** is true but **Statement II** is false

691121226. **Statement I** is false but **Statement II** is true

Question Number : 65 Question Id : 69112165 Question Type : MCQ Option Shuffling : Yes Display Question Number : Yes Is Question Mandatory : No Single Line Question Option : No Option Orientation : Vertical

In IUPAC nomenclature, the **correct** order of decreasing priority of functional group is :

Options :

691121227. $-\text{CONH}_2, >\text{C}=\text{O}, -\text{CHO}, -\text{NH}_2, -\text{C}\equiv\text{C}-$

691121228. $-\text{CONH}_2, -\text{COOCH}_3, -\text{CHO}, -\text{NH}_2, -\text{OH}$

691121229. $-\text{CONH}_2, -\text{CHO}, >\text{C}=\text{O}, -\text{NH}_2, -\text{C}\equiv\text{C}-$

691121230. $-\text{CONH}_2, -\text{CHO}, -\text{CN}, -\text{NH}_2, -\text{C}\equiv\text{C}-$

Question Number : 66 Question Id : 69112166 Question Type : MCQ Option Shuffling : Yes Display Question Number : Yes Is Question Mandatory : No Single Line Question Option : No Option Orientation : Vertical

For the given molecule, "x", the preferred site for the attack of the electrophile is :

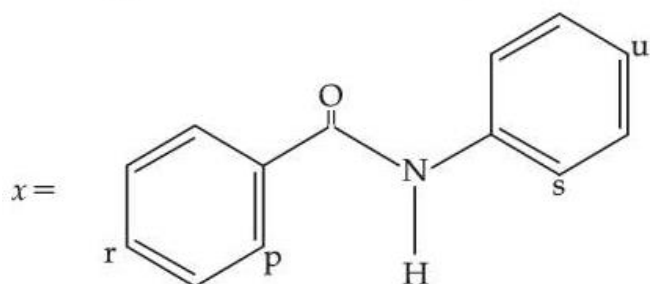

Options :

691121231. Predominantly at "r"

691121232. "r" and "u"

691121233. "p" and "s"

691121234. Predominantly at "u"

Question Number : 67 Question Id : 69112167 Question Type : MCQ Option Shuffling : Yes Display Question Number : Yes Is Question Mandatory : No Single Line Question Option : No Option Orientation : Vertical

Match List - I with List - II.

List - I

Mixture of Compounds

- A. Diethyl amine + Ethyl amine
 B. Acetaldehyde + Acetone
 C. Ethanol + Phenol
 D. Benzoic acid + Cinnamic acid

List - II

Reagent used to distinguish

- I. Bromine water
 II. $\text{CHCl}_3 + \text{KOH}, \Delta$
 III. Neutral FeCl_3
 IV. Ammonical silver nitrate

Choose the **correct** answer from the options given below :

Options :

691121235. A-IV, B-II, C-I, D-III

691121236. A-IV, B-II, C-III, D-I

691121237. A-II, B-IV, C-I, D-III

691121238. A-II, B-IV, C-III, D-I

Question Number : 68 Question Id : 69112168 Question Type : MCQ Option Shuffling : Yes Display Question Number : Yes Is Question Mandatory : No Single Line Question Option : No Option Orientation : Vertical

Consider the three aromatic molecules (P, Q and R) whose structures have been given below :

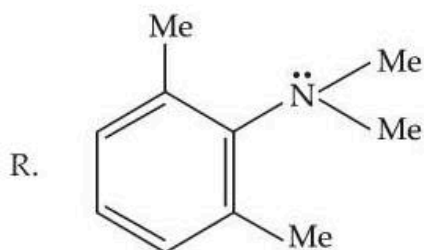
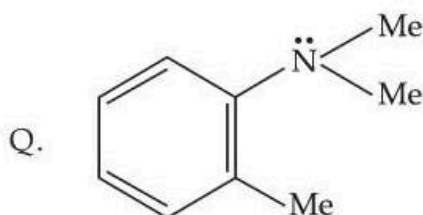
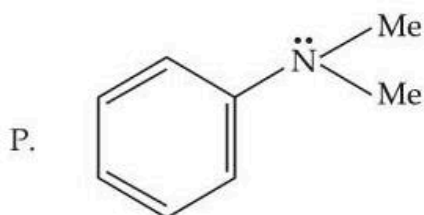

The **correct** order regarding the reactivity of these compounds with $\text{Ph}-\text{N} \equiv \text{N} \text{Cl}^{(-)}$ under optimum but slightly acidic medium is :

Options :

691121239. $P > Q > R$

691121240. $R > P > Q$

691121241. $R > Q > P$

$$P > R > Q$$

691121242.

Question Number : 69 Question Id : 69112169 Question Type : MCQ Option Shuffling : Yes Display Question Number : Yes Is Question Mandatory : No Single Line Question Option : No Option Orientation : Vertical

Match List - I with List - II.

List - I	List - II
Vitamin	Name
A. Vitamin B ₁	I. Pyridoxine
B. Vitamin B ₂	II. Ascorbic acid
C. Vitamin B ₆	III. Thiamine
D. Vitamin C	IV. Riboflavin

Choose the correct answer from the options given below :

Options :

691121243. A-II, B-I, C-III, D-IV

691121244. A-IV, B-III, C-II, D-I

691121245. A-III, B-IV, C-I, D-II

691121246. A-I, B-III, C-II, D-IV

Question Number : 70 Question Id : 69112170 Question Type : MCQ Option Shuffling : Yes Display Question Number : Yes Is Question Mandatory : No Single Line Question Option : No Option Orientation : Vertical

A salt with few drops of conc. HCl gives apple green colour in flame test. The group precipitate of the salt is dissolved in acetic acid and treated with K₂CrO₄ to give yellow precipitate. When the sodium carbonate extract of the salt solution is heated with conc. HNO₃ and ammonium molybdate, it resulted a canary yellow precipitate. The cation and anion present in the salt are respectively,

Options :

691121247. Ca²⁺ and SO₄²⁻691121248. Ba²⁺ and PO₄³⁻691121249. Mn²⁺ and PO₄³⁻691121250. Ba²⁺ and SO₄²⁻

Chemistry Section B

Section Id :	6911216
Section Number :	6
Section type :	Online
Mandatory or Optional :	Mandatory

Number of Questions :	5
Number of Questions to be attempted :	5
Section Marks :	20
Maximum Instruction Time :	0
Sub-Section Number :	1
Sub-Section Id :	6911216
Question Shuffling Allowed :	Yes
Is Section Default? :	No

Question Number : 71 Question Id : 69112171 Question Type : SA Display Question Number : Yes Keyboard Layout : Inscript

5.33 g of $\text{CrCl}_3 \cdot 6\text{H}_2\text{O}$, which is a 1 : 3 electrolyte, is dissolved in water and is passed through a cation exchanger. The chloride ions in the eluted solution, on treatment with AgNO_3 results in 8.61 g of AgCl . The ratio of moles of complex reacted and moles of AgCl formed is _____ $\times 10^{-2}$. (Nearest integer)

[Molar mass in g mol^{-1} Cr : 52, Ag : 108, Cl : 35.5, H : 1, O : 16]

Response Type : Numeric

Evaluation Required For SA : Yes

Show Word Count : Yes

Answers Type : Equal

Text Areas : PlainText

Possible Answers :

1

Question Number : 72 Question Id : 69112172 Question Type : SA Display Question Number : Yes Keyboard Layout : Inscript

Consider the isomers of hydrocarbon with molecular formula C_5H_{10} . These isomers do not decolourise KMnO_4 solution. These isomers are subjected to chlorination with chlorine in presence of light to give monochloro compounds. The total number of monochloro compounds (structural isomers only) formed is _____.

Response Type : Numeric

Evaluation Required For SA : Yes

Show Word Count : Yes

Answers Type : Equal

Text Areas : PlainText

Possible Answers :

1

Question Number : 73 Question Id : 69112173 Question Type : SA Display Question Number : Yes Keyboard Layout : Inscript

One mole of an alkane (x) requires 8 mole oxygen for complete combustion. Sum of number of carbon and hydrogen atoms in the alkane (x) is _____.

Response Type : Numeric

Evaluation Required For SA : Yes

Show Word Count : Yes

Answers Type : Equal

Text Areas : PlainText

Possible Answers :

1

Question Number : 74 Question Id : 69112174 Question Type : SA Display Question Number : Yes Keyboard Layout : Inscript

For reaction $\text{A} \rightarrow \text{P}$, rate constant $k = 1.5 \times 10^3 \text{ s}^{-1}$ at 27°C

If activation energy for the above reaction is 60 kJ mol^{-1} , then the temperature (in $^\circ\text{C}$) at which rate constant, $k = 4.5 \times 10^3 \text{ s}^{-1}$ is _____. (Nearest integer)

Given : $\log 2 = 0.30$, $\log 3 = 0.48$, $R = 8.3 \text{ J K}^{-1} \text{ mol}^{-1}$, $\ln 10 = 2.3$

Response Type : Numeric

Evaluation Required For SA : Yes

Show Word Count : Yes

Answers Type : Equal

Text Areas : PlainText

Possible Answers :

1

Question Number : 75 **Question Id :** 69112175 **Question Type :** SA **Display Question Number :** Yes **Keyboard Layout :** Inscript

At the transition temperature T, $A \rightleftharpoons B$ and $\Delta G^0 = 105 - 35 \log T$ where A and B are two states of substance X. The transition temperature in $^{\circ}\text{C}$ when pressure is 1 atm is _____.
(Nearest integer)

Response Type : Numeric

Evaluation Required For SA : Yes

Show Word Count : Yes

Answers Type : Equal

Text Areas : PlainText

Possible Answers :

1