

National Testing Agency

| | |
|-----------------------|-----------------------------|
| Question Paper Name : | B Tech 5th Apr 2026 Shift 1 |
| Subject Name : | B. Tech |
| Creation Date : | 2026-04-05 14:04:32 |
| Duration : | 180 |
| Total Marks : | 300 |
| Display Marks: | Yes |

B. Tech

| | |
|--------------------------|---------|
| Group Number : | 1 |
| Group Id : | 6952785 |
| Group Maximum Duration : | 0 |
| Group Minimum Duration : | 180 |
| Show Attended Group? : | No |
| Edit Attended Group? : | No |
| Break time : | 0 |
| Group Marks : | 300 |

Mathematics Section A

| | |
|---------------------------------------|-----------|
| Section Id : | 69527825 |
| Section Number : | 1 |
| Section type : | Online |
| Mandatory or Optional : | Mandatory |
| Number of Questions : | 20 |
| Number of Questions to be attempted : | 20 |
| Section Marks : | 80 |
| Maximum Instruction Time : | 0 |
| Sub-Section Number : | 1 |
| Sub-Section Id : | 69527825 |
| Question Shuffling Allowed : | Yes |
| Is Section Default? : | No |

Question Number : 1 Question Id : 695278301 Question Type : MCQ Option Shuffling : Yes Display Question Number : Yes Is Question Mandatory : No Single Line Question Option : No Option Orientation : Vertical

Let $a, b \in \mathbb{C}$. Let α, β be the roots of the equation $x^2 + ax + b = 0$. If $\beta - \alpha = \sqrt{11}$ and $\beta^2 - \alpha^2 = 3i\sqrt{11}$, then $(\beta^3 - \alpha^3)^2$ is equal to:

Options :

6952781021. 160

6952781022. 176

6952781023. 194

6952781024. 187

Question Number : 2 Question Id : 695278302 Question Type : MCQ Option Shuffling : Yes Display Question Number : Yes Is Question Mandatory : No Single Line Question Option : No Option Orientation : Vertical

Let the sum of the first n terms of an A.P. be $3n^2 + 5n$. Then the sum of squares of the first 10 terms of the A.P. is:

Options :

6952781025. 10220

6952781026. 12860

6952781027. 15220

6952781028. 19780

Question Number : 3 Question Id : 695278303 Question Type : MCQ Option Shuffling : Yes Display Question Number : Yes Is Question Mandatory : No Single Line Question Option : No Option Orientation : Vertical

Let A be a 3×3 matrix such that

$$A^T \begin{bmatrix} 1 \\ 0 \\ 1 \end{bmatrix} = \begin{bmatrix} 5 \\ 2 \\ 2 \end{bmatrix}, A^T \begin{bmatrix} 0 \\ 0 \\ 1 \end{bmatrix} = \begin{bmatrix} 3 \\ 1 \\ 1 \end{bmatrix}, A \begin{bmatrix} 1 \\ 0 \\ 1 \end{bmatrix} = \begin{bmatrix} 3 \\ 4 \\ 4 \end{bmatrix} \text{ and } A \begin{bmatrix} 0 \\ 0 \\ 1 \end{bmatrix} = \begin{bmatrix} 1 \\ 3 \\ 1 \end{bmatrix}.$$

If $\det(A) = 1$, then $\det(\text{adj}(A^2 + A))$ is equal to:

Options :

6952781029. 16

6952781030. 25

6952781031. 49

6952781032. 64

Question Number : 4 Question Id : 695278304 Question Type : MCQ Option Shuffling : Yes Display Question Number : Yes Is Question Mandatory : No Single Line Question Option : No Option Orientation : Vertical

Consider the system of linear equations in x, y, z :

$$x + 2y + tz = 0,$$

$$6x + y + 5tz = 0,$$

$$3x + t^2y + f(t)z = 0,$$

where $f: \mathbb{R} \rightarrow \mathbb{R}$ is a differentiable function. If this system has infinitely many solutions for all $t \in \mathbb{R}$, then f

Options :

6952781033. is a constant function

6952781034. is strictly increasing on \mathbb{R}

6952781035. is strictly decreasing on \mathbb{R}

6952781036. has two critical points

Question Number : 5 Question Id : 695278305 Question Type : MCQ Option Shuffling : Yes Display Question Number : Yes Is Question Mandatory : No Single Line Question Option : No Option Orientation : Vertical

$$\sum_{n=1}^{10} \left(\frac{528}{n(n+1)(n+2)} \right) \text{ is equal to:}$$

Options :

6952781037. 65

6952781038. 130

6952781039. 220

6952781040. 440

Question Number : 6 Question Id : 695278306 Question Type : MCQ Option Shuffling : Yes Display Question Number : Yes Is Question Mandatory : No Single Line Question Option : No Option Orientation : Vertical

Let $\tan A, \tan B$, where $A, B \in \left(-\frac{\pi}{2}, \frac{\pi}{2}\right)$, be the roots of the quadratic equation $x^2 - 2x - 5 = 0$. Then $20 \sin^2\left(\frac{A+B}{2}\right)$ is equal to:

Options :

6952781041. $10 + \sqrt{10}$

6952781042. $10 - 2\sqrt{10}$

6952781043. $10 - 3\sqrt{10}$

6952781044. $10 - \sqrt{10}$

Question Number : 7 Question Id : 695278307 Question Type : MCQ Option Shuffling : Yes Display Question Number : Yes Is Question Mandatory : No Single Line Question Option : No Option Orientation : Vertical

A letter is known to have arrived by post either from KANPUR or from ANANTPUR. On the envelope just two consecutive letters AN are visible. The probability, that the letter came from ANANTPUR, is:

Options :

6952781045. $\frac{7}{10}$

6952781046. $\frac{10}{17}$

6952781047. $\frac{12}{19}$

6952781048. $\frac{7}{19}$

Question Number : 8 Question Id : 695278308 Question Type : MCQ Option Shuffling : Yes Display Question Number : Yes Is Question Mandatory : No Single Line Question Option : No Option Orientation : Vertical

The mean deviation about the mean for the data

| | | | | | | |
|-------|---|---|---|----|----|----|
| x_i | 5 | 7 | 9 | 10 | 12 | 15 |
| f_i | 8 | 6 | 2 | 2 | 2 | 6 |

is equal to:

Options :

40

6952781049. 13

42

6952781050. 13

44

6952781051. 13

46

6952781052. 13

Question Number : 9 Question Id : 695278309 Question Type : MCQ Option Shuffling : Yes Display Question Number : Yes Is Question Mandatory : No Single Line Question Option : No Option Orientation : Vertical

Let a focus of the ellipse $E : \frac{x^2}{a^2} + \frac{y^2}{b^2} = 1$ be $S(4, 0)$ and its eccentricity be $\frac{4}{5}$. If the point $P(3, \alpha)$ lies on E and O is the origin, then the area of ΔPOS is equal to:

Options :

6952781053. 12/5

6952781054. 14/5

6952781055. 24/5

6952781056. 48/5

Question Number : 10 Question Id : 695278310 Question Type : MCQ Option Shuffling : Yes Display Question Number : Yes Is Question Mandatory : No Single Line Question Option : No Option Orientation : Vertical

Let P be a moving point on the circle $x^2 + y^2 - 6x - 8y + 21 = 0$. Then, the maximum distance of P from the vertex of the parabola $x^2 + 6x + y + 13 = 0$ is equal to:

Options :

6952781057. 8

6952781058. 10

6952781059. 12

6952781060. 9

Question Number : 11 Question Id : 695278311 Question Type : MCQ Option Shuffling : Yes Display Question Number : Yes Is Question Mandatory : No Single Line Question Option : No Option Orientation : Vertical

In an equilateral triangle PQR , let the vertex P be at $(3, 5)$ and the side QR be along the line $x + y = 4$. If the orthocentre of the triangle PQR is (α, β) , then $9(\alpha + \beta)$ is equal to:

Options :

6952781061. 16

6952781062. 27

6952781063. 36

6952781064. 48

Question Number : 12 Question Id : 695278312 Question Type : MCQ Option Shuffling : Yes Display Question Number : Yes Is Question Mandatory : No Single Line Question Option : No Option Orientation : Vertical

The sum of all the integral values of p such that the equation $3\sin^2 x + 12\cos x - 3 = p$, $x \in \mathbb{R}$, has at least one solution, is:

Options :

6952781065. -54

6952781066. -60

6952781067. -75

6952781068. -84

Question Number : 13 Question Id : 695278313 Question Type : MCQ Option Shuffling : Yes Display Question Number : Yes Is Question Mandatory : No Single Line Question Option : No Option Orientation : Vertical

The square of the distance of the point $P(5, 6, 7)$ from the line $\frac{x-2}{2} = \frac{y-5}{3} = \frac{z-2}{4}$ is equal to:

Options :

6952781069. 3

6952781070. 5

6952781071. 6

6952781072. 8

Question Number : 14 Question Id : 695278314 Question Type : MCQ Option Shuffling : Yes Display Question Number : Yes Is Question Mandatory : No Single Line Question Option : No Option Orientation : Vertical

Let $\vec{a} = \sqrt{7}\hat{i} + \hat{j} - \hat{k}$ and $\vec{b} = \hat{j} + 2\hat{k}$. If \vec{r} is a vector such that $\vec{r} \times \vec{a} + \vec{a} \times \vec{b} = \vec{0}$ and $\vec{r} \cdot \vec{a} = 0$, then $|3\vec{r}|^2$ is equal to:

Options :

6952781073. 44

6952781074. 54

6952781075. 86

6952781076. 132

Question Number : 15 Question Id : 695278315 Question Type : MCQ Option Shuffling : Yes Display Question Number : Yes Is Question Mandatory : No Single Line Question Option : No Option Orientation : Vertical

The square of the distance of the point of intersection of the lines $\vec{r} = (\hat{i} + \hat{j} - \hat{k}) + \lambda(\hat{a}\hat{i} - \hat{j})$, $a \neq 0$ and $\vec{r} = (4\hat{i} - \hat{k}) + \mu(2\hat{i} + a\hat{k})$ from the origin is:

Options :

6952781077. 5

6952781078. 10

6952781079. 17

6952781080. 26

Question Number : 16 Question Id : 695278316 Question Type : MCQ Option Shuffling : Yes Display Question Number : Yes Is Question Mandatory : No Single Line Question Option : No Option Orientation : Vertical

The area of the region $R = \{(x, y): xy \leq 27, 1 \leq y \leq x^2\}$ is equal to:

Options :

6952781081. $78 \log_e 3 - \frac{52}{3}$

6952781082. $54 \log_e 3 - \frac{52}{3}$

6952781083. $54 \log_e 3 - \frac{26}{3}$

6952781084. $54 \log_e 3 + \frac{26}{3}$

Question Number : 17 Question Id : 695278317 Question Type : MCQ Option Shuffling : Yes Display Question Number : Yes Is Question Mandatory : No Single Line Question Option : No Option Orientation : Vertical

The product of all possible values of α , for which

$$\lim_{x \rightarrow 0} \left(\frac{1 - \cos(\alpha x) \cos((\alpha + 1)x) \cos((\alpha + 2)x)}{\sin^2((\alpha + 1)x)} \right) = 2, \text{ is:}$$

Options :

6952781085. -2

6952781086. 1

6952781087. -1

6952781088. $\frac{5}{4}$

Question Number : 18 Question Id : 695278318 Question Type : MCQ Option Shuffling : Yes Display Question Number : Yes Is Question Mandatory : No Single Line Question Option : No Option Orientation : Vertical

The value of the integral $\int_0^\infty \frac{\log_e(x)}{x^2 + 4} dx$ is:

Options :

6952781089. $\frac{\pi \log_e(2)}{2}$

6952781090. $\frac{\pi \log_e(2)}{4}$

6952781091. $1 + \pi \log_e(2)$

6952781092. $2 + \pi \log_e(2)$

Question Number : 19 Question Id : 695278319 Question Type : MCQ Option Shuffling : Yes Display Question Number : Yes Is Question Mandatory : No Single Line Question Option : No Option Orientation : Vertical

Let $f: \mathbb{R} \rightarrow \mathbb{R}$ be a differentiable function such that $f\left(\frac{x+y}{3}\right) = \frac{f(x)+f(y)}{3}$

for all $x, y \in \mathbb{R}$, and $f'(0) = 3$. Then the minimum value of the function

$g(x) = 3 + e^x f(x)$, is:

Options :

6952781093. $3\left(\frac{e+1}{e}\right)$

6952781094. $3\left(\frac{e-1}{e}\right)$

6952781095. $\frac{3-e}{e}$

6952781096. $3e$

Question Number : 20 Question Id : 695278320 Question Type : MCQ Option Shuffling : Yes Display Question Number : Yes Is Question Mandatory : No Single Line Question Option : No Option Orientation : Vertical

The value of the integral $\int_{\frac{\pi}{6}}^{\frac{\pi}{3}} \left(\frac{4 - \operatorname{cosec}^2 x}{\cos^4 x} \right) dx$ is:

Options :

6952781097. $\frac{11}{\sqrt{3}}$

6952781098. $\frac{16}{\sqrt{3}}$

6952781099. $\frac{32}{3\sqrt{3}}$

6952781100. $\frac{64}{3\sqrt{3}}$

Mathematics Section B

| | |
|--|-----------|
| Section Id : | 69527826 |
| Section Number : | 2 |
| Section type : | Online |
| Mandatory or Optional : | Mandatory |
| Number of Questions : | 5 |
| Number of Questions to be attempted : | 5 |

| | |
|------------------------------|----------|
| Section Marks : | 20 |
| Maximum Instruction Time : | 0 |
| Sub-Section Number : | 1 |
| Sub-Section Id : | 69527826 |
| Question Shuffling Allowed : | Yes |
| Is Section Default? : | No |

Question Number : 21 Question Id : 695278321 Question Type : SA Display Question Number : Yes Keyboard Layout : Inscript

Let $A = \{1, 2, 3, 4, 5, 6\}$. The number of one-one functions $f: A \rightarrow A$ such that $f(1) \geq 3, f(3) \leq 4$ and $f(2) + f(3) = 5$, is _____.

Response Type : Numeric

Evaluation Required For SA : Yes

Show Word Count : Yes

Answers Type : Equal

Text Areas : PlainText

Possible Answers :

1

Question Number : 22 Question Id : 695278322 Question Type : SA Display Question Number : Yes Keyboard Layout : Inscript

Two players A and B play a series of games of badminton. The player, who wins 5 games first, wins the series. Assuming that no game ends in a draw, the number of ways, in which player A wins the series is _____.

Response Type : Numeric

Evaluation Required For SA : Yes

Show Word Count : Yes

Answers Type : Equal

Text Areas : PlainText

Possible Answers :

1

Question Number : 23 Question Id : 695278323 Question Type : SA Display Question Number : Yes Keyboard Layout : Inscript

If the sum of the coefficients of x^7 and x^{14} in the expansion of

$\left(\frac{1}{x^3} - x^4\right)^n$, $x \neq 0$, is zero, then the value of n is _____.

Response Type : Numeric

Evaluation Required For SA : Yes

Show Word Count : Yes

Answers Type : Equal

Text Areas : PlainText

Possible Answers :

1

Question Number : 24 Question Id : 695278324 Question Type : SA Display Question Number : Yes Keyboard Layout : Inscript

If $\frac{\pi}{4} + \sum_{p=1}^{11} \tan^{-1}\left(\frac{2^{p-1}}{1+2^{2^{p-1}}}\right) = \alpha$, then $\tan \alpha$ is equal to _____.

Response Type : Numeric

Evaluation Required For SA : Yes

Show Word Count : Yes

Answers Type : Equal

Text Areas : PlainText

Possible Answers :

1

Question Number : 25 Question Id : 695278325 Question Type : SA Display Question Number : Yes Keyboard Layout : Inscript

Let $y = y(x)$ be the solution of the differential equation

$$x \sin\left(\frac{y}{x}\right) dy = \left(y \sin\left(\frac{y}{x}\right) - x\right) dx, y(1) = \frac{\pi}{2} \text{ and let } \alpha = \cos\left(\frac{y(e^{12})}{e^{12}}\right). \text{ Then}$$

the number of integral value of p , for which the equation

$$x^2 + y^2 - 2px + 2py + \alpha + 2 = 0 \text{ represents a circle of radius } r \leq 6, \text{ is } \underline{\hspace{2cm}}.$$

Response Type : Numeric

Evaluation Required For SA : Yes

Show Word Count : Yes

Answers Type : Equal

Text Areas : PlainText

Possible Answers :

1

Physics Section A

| | |
|---------------------------------------|-----------|
| Section Id : | 69527827 |
| Section Number : | 3 |
| Section type : | Online |
| Mandatory or Optional : | Mandatory |
| Number of Questions : | 20 |
| Number of Questions to be attempted : | 20 |
| Section Marks : | 80 |
| Maximum Instruction Time : | 0 |
| Sub-Section Number : | 1 |
| Sub-Section Id : | 69527827 |
| Question Shuffling Allowed : | Yes |
| Is Section Default? : | No |

Question Number : 26 Question Id : 695278326 Question Type : MCQ Option Shuffling : Yes Display Question Number : Yes Is Question Mandatory : No Single Line Question Option : No Option Orientation : Vertical

In a Vernier calipers, when both jaws touch each other, zero of the Vernier scale is shifted to the right of zero of the main scale and 7th Vernier division coincides with a main scale reading. If the value of 1 main scale division is 1 mm and there are 10 Vernier scale divisions, then the Vernier caliper has

Options :

6952781106. 0.07 cm negative zero error

6952781107. 0.7 cm negative zero error

6952781108. 0.07 cm positive zero error

6952781109. 0.7 cm positive zero error

Question Number : 27 Question Id : 695278327 Question Type : MCQ Option Shuffling : Yes Display Question Number : Yes Is Question Mandatory : No Single Line Question Option : No Option Orientation : Vertical

L , C and R represents physical quantities inductance, capacitance and resistance respectively. The dimensional formula $M L^2 T^{-4} A^{-2}$ corresponds to _____.

Options :

6952781110. $\frac{R}{\sqrt{LC}}$

6952781111. $\frac{R}{LC}$

6952781112. $\frac{C}{\sqrt{LR}}$

6952781113. $\frac{1}{R} \sqrt{\frac{L}{C}}$

Question Number : 28 Question Id : 695278328 Question Type : MCQ Option Shuffling : Yes Display Question Number : Yes Is Question Mandatory : No Single Line Question Option : No Option Orientation : Vertical

When one moves from a point 16 km below the earth's surface to a point 16 km above the earth's surface. The change in g is approximately α %. The value of α is _____.

(Take radius of the earth = 6400 km.)

Options :

6952781114. 0.12

6952781115. 0.25

6952781116. 0.50

6952781117. 0.75

Question Number : 29 Question Id : 695278329 Question Type : MCQ Option Shuffling : Yes Display Question Number : Yes Is Question Mandatory : No Single Line Question Option : No Option Orientation : Vertical

Three masses $m_1 = 4$ kg, $m_2 = 4$ kg and $m_3 = 6$ kg are suspended from a fixed smooth frictionless pulley as shown in the figure below. The value of T_1/T_2 is

(take $g = 10$ m/s²)

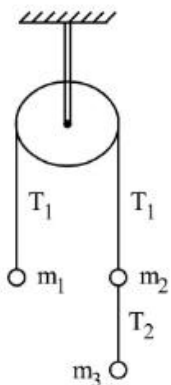

Options :

6952781118. $5/3$

6952781119. $2/3$

6952781120. 3/5

6952781121. 2/5

Question Number : 30 Question Id : 695278330 Question Type : MCQ Option Shuffling : Yes Display Question Number : Yes Is Question Mandatory : No Single Line Question Option : No Option Orientation : Vertical

A wedge Y with mass of 10 kg and all frictionless surfaces and the inclined surface making 37° with horizontal. A block X with mass 2 kg is placed at the highest point of the wedge as shown in figure is at rest. At $t = 0$ wedge (Y) is pulled toward right with constant force (f) of 24 N. Taking the block X at rest at $t = 0$, the time taken by it to slide down 8.8 m on the slope, while Y is on the move, is _____ s.

(take $\tan(37^\circ) = 3/4$ and $g = 10 \text{ m/s}^2$)

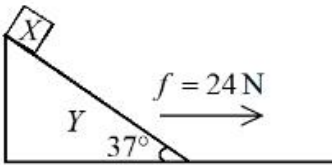

Options :

6952781122. 2

6952781123. 4

6952781124. $\sqrt{2}$

6952781125. $2\sqrt{2}$

Question Number : 31 Question Id : 695278331 Question Type : MCQ Option Shuffling : Yes Display Question Number : Yes Is Question Mandatory : No Single Line Question Option : No Option Orientation : Vertical

The Young's modulus of steel wire of radius r and length L is Y .

If the radius r and length L of the wire are doubled then the value of Y

Options :

6952781126. increases by two times

6952781127. reduces by half

6952781128. remains unchanged

6952781129. becomes one fourth

Question Number : 32 Question Id : 695278332 Question Type : MCQ Option Shuffling : Yes Display Question Number : Yes Is Question Mandatory : No Single Line Question Option : No Option Orientation : Vertical

Given below are two statements: one is labelled as **Assertion A** and the other is labelled as **Reason R**

Statement I: Change in internal energy of a system containing n mole of ideal

gas can be written as $\Delta U = n C_v (T_f - T_i) = \frac{nR}{\gamma - 1} (T_f - T_i)$, where

$\gamma = \frac{C_p}{C_v}$, T_i = initial temperature, T_f = final temperature.

Statement II: Relation between degree of freedom f and $\gamma (= C_p/C_v)$ is

$$\left(\gamma = 1 + \frac{2}{f} \right)$$

Choose the **correct** answer from the options given below

Options :

6952781130. Both **A** and **R** are true and **R** is the correct explanation of **A**

6952781131. Both **A** and **R** are true but **R** is **NOT** the correct explanation of **A**

6952781132. **A** is true but **R** is false

6952781133. **A** is false but **R** is true

Question Number : 33 Question Id : 695278333 Question Type : MCQ Option Shuffling : Yes Display Question Number : Yes Is Question Mandatory : No Single Line Question Option : No Option Orientation : Vertical

Consider the following statements:

- A. Zeroth law of thermodynamics gives concept of temperature
- B. First law of thermodynamics gives concept of internal energy
- C. In isothermal expansion of ideal gas, $\Delta Q \neq \Delta W$
- D. Product of intensive and extensive variables is extensive
- E. The ratio of any extensive variable to mass will be an extensive variable

Choose the correct combination of statements from the options given below:

Options :

6952781134. C, D and E Only

6952781135. A, B and C Only

6952781136. A, B and D Only

6952781137. B, C and D Only

Question Number : 34 Question Id : 695278334 Question Type : MCQ Option Shuffling : Yes Display Question Number : Yes Is Question Mandatory : No Single Line Question Option : No Option Orientation : Vertical

Refer to the figure given below. The values of I_1 , I_2 and I_3 are _____.

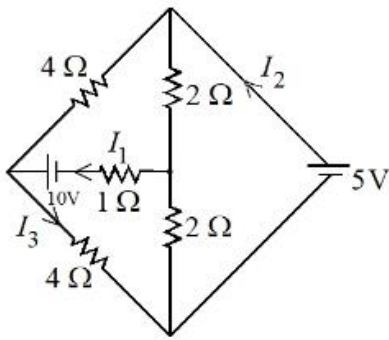

Options :

6952781138. $I_1 = 2.5 \text{ A}, I_2 = 1.875 \text{ A}, I_3 = 1.875 \text{ A}$

6952781139. $I_1 = 1.875 \text{ A}, I_2 = 2.5 \text{ A}, I_3 = 1.875 \text{ A}$

6952781140. $I_1 = 1.875 \text{ A}, I_2 = 1.875 \text{ A}, I_3 = 2.5 \text{ A}$

6952781141. $I_1 = 2.5 \text{ A}, I_2 = 2.5 \text{ A}, I_3 = 1.875 \text{ A}$

Question Number : 35 Question Id : 695278335 Question Type : MCQ Option Shuffling : Yes Display Question Number : Yes Is Question Mandatory : No Single Line Question Option : No Option Orientation : Vertical

An electron of mass m is moving in an electric

field $\vec{E} = -2E_0\hat{j}$ ($E_0 = \text{constant} > 0$), with an initial velocity $\vec{V} = v_0\hat{j}$

($v_0 = \text{constant} > 0$). If $\lambda_0 = \frac{h}{4mv_0}$, its de Broglie wavelength at time t is

_____.
($e = \text{charge of electron}$)

Options :

6952781142. $\frac{4\lambda_0}{\left[1 - \frac{E_0 e t}{2m v_0}\right]}$

6952781143. $\frac{4\lambda_0}{\left[1 + \frac{E_0 e t}{2m v_0}\right]}$

6952781144. $\frac{4\lambda_0}{\left[1 + \frac{2E_0 e t}{m v_0}\right]}$

6952781145. $\frac{4\lambda_0}{\left[1 - \frac{2E_0 e t}{m v_0}\right]}$

Question Number : 36 Question Id : 695278336 Question Type : MCQ Option Shuffling : Yes Display Question Number : Yes Is Question Mandatory : No Single Line Question Option : No Option Orientation : Vertical

In the hydrogen atom, the electron makes a transition from the higher orbit (i) to a lower orbit (f). The ratio of the radius of the orbits is given by $r_i : r_f = 16 : 4$.

The wavelength of photon emitted due to this transition is _____ nm.

(Given Rydberg constant = $1.0973 \times 10^7 / \text{m}$)

Options :

6952781146. 121

6952781147. 242

6952781148. 486

6952781149. 974

Question Number : 37 Question Id : 695278337 Question Type : MCQ Option Shuffling : Yes Display Question Number : Yes Is Question Mandatory : No Single Line Question Option : No Option Orientation : Vertical

A displacement current of 4.0 A can be set up in the space between two parallel plates of 6 μF capacitor. The rate of change of potential difference across the plates of the capacitor is nearly $\alpha \times 10^6$ V/s. The value of α is _____.

Options :

6952781150. 0.58

6952781151. 0.67

6952781152. 0.82

6952781153. 0.75

Question Number : 38 Question Id : 695278338 Question Type : MCQ Option Shuffling : Yes Display Question Number : Yes Is Question Mandatory : No Single Line Question Option : No Option Orientation : Vertical

Refer to the figure given below, current between terminals A and B is

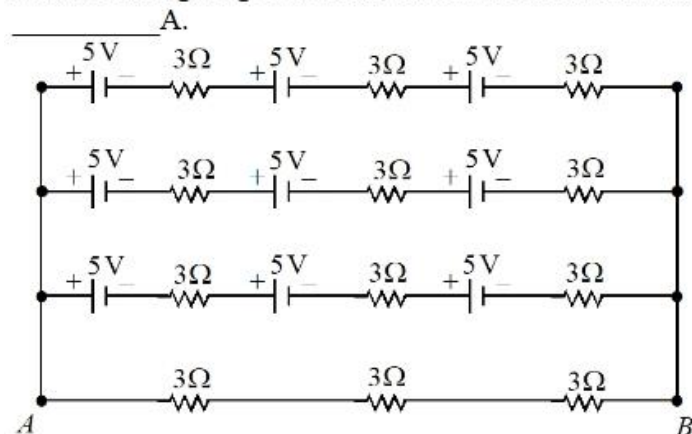

Options :

6952781154. 12.5

6952781155. 1.25

6952781156. 7.5

6952781157. 5

Question Number : 39 Question Id : 695278339 Question Type : MCQ Option Shuffling : Yes Display Question Number : Yes Is Question Mandatory : No Single Line Question Option : No Option Orientation : Vertical

In Young's double slit experiment, the fringe width of the interference pattern produced on the screen is $2.4 \mu\text{m}$. If the experiment is carried out in another medium having refractive index 1.2, the fringe width will be ____ μm .

Options :

- 6952781158. 1.2
- 6952781159. 2
- 6952781160. 2.4
- 6952781161. 2.88

Question Number : 40 Question Id : 695278340 Question Type : MCQ Option Shuffling : Yes Display Question Number : Yes Is Question Mandatory : No Single Line Question Option : No Option Orientation : Vertical

A ray of light passing through an equilateral prism is having velocity $2.12 \times 10^8 \text{ m/s}$ in the prism material, then the minimum angle of deviation is _____ degrees.

Options :

- 6952781162. 45
- 6952781163. 30
- 6952781164. 28
- 6952781165. 58

Question Number : 41 Question Id : 695278341 Question Type : MCQ Option Shuffling : Yes Display Question Number : Yes Is Question Mandatory : No Single Line Question Option : No Option Orientation : Vertical

Light source having wavelength 331 nm is used to generate photo-electrons whose stopping potential is 0.2 V. The work function of the used metal in the experiment is $a \times 10^{-19} \text{ J}$. The value of a is _____.
($h = 6.62 \times 10^{-34} \text{ J s}$, $e = 1.6 \times 10^{-19} \text{ C}$ and $c = 3 \times 10^8 \text{ m/s}$)

Options :

- 6952781166. 3.68
- 6952781167. 4.68
- 6952781168. 5.68
- 6952781169. 2.68

Question Number : 42 Question Id : 695278342 Question Type : MCQ Option Shuffling : Yes Display Question Number : Yes Is Question Mandatory : No Single Line Question Option : No Option Orientation : Vertical

A compound microscope is designed with two symmetric biconvex lenses. The objective lens is cut vertically, creating two identical plano-convex lenses. One of them is used in place of original objective lens. To retain same magnification keeping the object distance unchanged, the tube length has to be

Options :

- 6952781170. increased two times

6952781171. increased $\frac{3}{2}$ times

6952781172. decreased two times

6952781173. decreased $\frac{3}{2}$ times

Question Number : 43 Question Id : 695278343 Question Type : MCQ Option Shuffling : Yes Display Question Number : Yes Is Question Mandatory : No Single Line Question Option : No Option Orientation : Vertical

Two wires as shown in the figure below, made of steel and have breaking stress of $12 \times 10^8 \text{ N/m}^2$. Area of cross-section of upper wire is 0.008 cm^2 and of lower wire is 0.004 cm^2 . The maximum mass that can be added to pan without breaking any wire is _____ kg.

(take $g = 10 \text{ m/s}^2$)

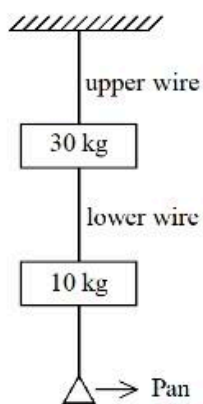

Options :

6952781174. 56

6952781175. 38

6952781176. 96

6952781177. 5.6

Question Number : 44 Question Id : 695278344 Question Type : MCQ Option Shuffling : Yes Display Question Number : Yes Is Question Mandatory : No Single Line Question Option : No Option Orientation : Vertical

An a.c. source of angular frequency ω is connected across a resistor R and a capacitor C in series. The current is observed as I . Now the frequency of the source is changed to $\omega/4$, (keeping the voltage unchanged) the current is found to be $I/3$. The ratio of resistance to reactance at frequency ω is

Options :

6952781178. $\sqrt{\frac{6}{7}}$

6952781179. $\sqrt{\frac{3}{5}}$

6952781180. $\sqrt{\frac{7}{8}}$

6952781181. $\sqrt{\frac{3}{4}}$

Question Number : 45 Question Id : 695278345 Question Type : MCQ Option Shuffling : Yes Display Question Number : Yes Is Question Mandatory : No Single Line Question Option : No Option Orientation : Vertical

For the given logic circuit, which of the following inputs combination will make both LED-1 and LED-2 to glow?

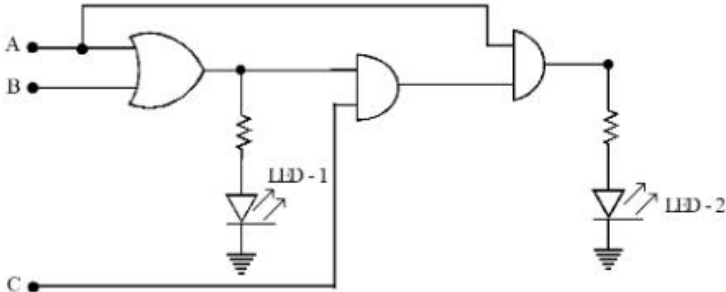

Options :

6952781182. A = 0, B = 1, C = 1

6952781183. A = 1, B = 0, C = 0

6952781184. A = 1, B = 0, C = 1

6952781185. A = 1, B = 1, C = 0

Physics Section B

| | |
|--|-----------|
| Section Id : | 69527828 |
| Section Number : | 4 |
| Section type : | Online |
| Mandatory or Optional : | Mandatory |
| Number of Questions : | 5 |
| Number of Questions to be attempted : | 5 |
| Section Marks : | 20 |
| Maximum Instruction Time : | 0 |
| Sub-Section Number : | 1 |
| Sub-Section Id : | 69527828 |
| Question Shuffling Allowed : | Yes |
| Is Section Default? : | No |

Question Number : 46 Question Id : 695278346 Question Type : SA Display Question Number : Yes Keyboard Layout : Inscript

A cube has side length 5 cm and modulus of rigidity 10^5 N/m^2 . The displacement produced by a force of 10 N in the upper face of cube is _____ mm.

Response Type : Numeric

Evaluation Required For SA : Yes

Show Word Count : Yes

Answers Type : Equal

Text Areas : PlainText

Possible Answers :

1

Question Number : 47 Question Id : 695278347 Question Type : SA Display Question Number : Yes Keyboard Layout : Inscript

From 18 m height above the ground a ball is dropped from rest . The height above the ground at which the magnitude of velocity equal to the magnitude of acceleration (in the same set of units) due to gravity is ____ m.

(Take $g = 10 \text{ m/s}^2$ and neglect the air resistance)

Response Type : Numeric

Evaluation Required For SA : Yes

Show Word Count : Yes

Answers Type : Equal

Text Areas : PlainText

Possible Answers :

1

Question Number : 48 Question Id : 695278348 Question Type : SA Display Question Number : Yes Keyboard Layout : Inscript

A transverse wave on a string is described by $y = 3\sin(36t + 0.018x + \pi/4)$, where x, y are in cm and t in seconds. The least distance between the two successive crests in the wave is ____ cm. (Nearest integer)

($\pi = 3.14$)

Response Type : Numeric

Evaluation Required For SA : Yes

Show Word Count : Yes

Answers Type : Equal

Text Areas : PlainText

Possible Answers :

1

Question Number : 49 Question Id : 695278349 Question Type : SA Display Question Number : Yes Keyboard Layout : Inscript

The charged particle moving in a uniform magnetic field of $(3\hat{i} + 2\hat{j})\text{T}$ has an

acceleration $\left(4\hat{i} - \frac{x}{2}\hat{j}\right)\text{m/s}^2$. The value of x is

Response Type : Numeric

Evaluation Required For SA : Yes

Show Word Count : Yes

Answers Type : Equal

Text Areas : PlainText

Possible Answers :

1

Question Number : 50 Question Id : 695278350 Question Type : SA Display Question Number : Yes Keyboard Layout : Inscript

In the given circuit below inductance values of L_1, L_2 and L_3 are same. The magnetic energy stored in the entire circuit is (U_t) and that stored in the L_2 inductor is (U_l) . U_t / U_l is _____.

(Ignore the mutual inductance if any)

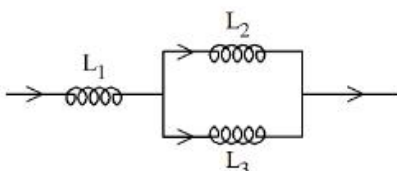

Response Type : Numeric

Evaluation Required For SA : Yes

Show Word Count : Yes

Answers Type : Equal

Text Areas : PlainText

Possible Answers :

1

Chemistry Section A

| | |
|---------------------------------------|-----------|
| Section Id : | 69527829 |
| Section Number : | 5 |
| Section type : | Online |
| Mandatory or Optional : | Mandatory |
| Number of Questions : | 20 |
| Number of Questions to be attempted : | 20 |
| Section Marks : | 80 |
| Maximum Instruction Time : | 0 |
| Sub-Section Number : | 1 |
| Sub-Section Id : | 69527829 |
| Question Shuffling Allowed : | Yes |
| Is Section Default? : | No |

Question Number : 51 Question Id : 695278351 Question Type : MCQ Option Shuffling : Yes Display Question Number : Yes Is Question Mandatory : No Single Line Question Option : No Option Orientation : Vertical

How many grams of residue is obtained by heating 2.76 g of silver carbonate?

(Given : Molar mass of C, O and Ag are 12, 16 and 108 g mol⁻¹ respectively)

Options :

6952781191. 1.08 g

6952781192. 2.16 g

6952781193. 3.24 g

6952781194. 4.32 g

Question Number : 52 Question Id : 695278352 Question Type : MCQ Option Shuffling : Yes Display Question Number : Yes Is Question Mandatory : No Single Line Question Option : No Option Orientation : Vertical

Arrange the following atomic orbitals of multi electron atoms in order of increasing energy.

A. $n = 3, l = 2, m = +1$

B. $n = 4, l = 0, m = 0$

C. $n = 6, l = 1, m = 0$

D. $n = 5, l = 1, m = +1$

E. $n = 2, l = 1, m = +1$

Choose the correct answer from the options given below:

Options :

6952781195. C < D < B < A < E

6952781196. B < A < E < C < D

6952781197. E < C < D < B < A

6952781198. $E < B < A < D < C$

Question Number : 53 Question Id : 695278353 Question Type : MCQ Option Shuffling : Yes Display Question Number : Yes Is Question Mandatory : No Single Line Question Option : No Option Orientation : Vertical

Identify the correct statements from the following :

- A. Heisenberg uncertainty principle is applicable to electrons.
- B. The size of $2p_x$ orbital is less than the size of $3p_x$ orbital.
- C. The energy of 2s orbital of H atom is equal to the energy of 2s orbital of Li.
- D. The electronic configuration of Cr is $[\text{Ar}] 3d^5 4s^1$

Choose the correct answer from the options given below:

Options :

6952781199. A, B and C Only

6952781200. A, B and D Only

6952781201. B, C and D Only

6952781202. A, C and D Only

Question Number : 54 Question Id : 695278354 Question Type : MCQ Option Shuffling : Yes Display Question Number : Yes Is Question Mandatory : No Single Line Question Option : No Option Orientation : Vertical

What is the mole fraction of water in 10% by weight (w/w) of aqueous urea solution?

[Given: Molar mass of H, O, C and N are 1, 16, 12 and 14 g mol^{-1} respectively.]

Options :

6952781203. 0.825

6952781204. 0.032

6952781205. 0.867

6952781206. 0.967

Question Number : 55 Question Id : 695278355 Question Type : MCQ Option Shuffling : Yes Display Question Number : Yes Is Question Mandatory : No Single Line Question Option : No Option Orientation : Vertical

M_3A_2 is a sparingly soluble salt of molar mass $y \text{ g mol}^{-1}$ and solubility $x \text{ g L}^{-1}$.

The ratio of the molar concentration of the anion (A^{3-}) to the solubility product of the salt is

Options :

6952781207. $\frac{1}{54} \cdot \frac{y^4}{x^4}$

6952781208. $\frac{y^5}{108x^4}$

6952781209. $108 \cdot \frac{x^5}{y^5}$

6952781210. $\frac{1}{108} \frac{y^4}{x^4}$

Question Number : 56 Question Id : 695278356 Question Type : MCQ Option Shuffling : Yes Display Question Number : Yes Is Question Mandatory : No Single Line Question Option : No Option Orientation : Vertical

Arrange the following resultant mixtures in increasing order of their pH values

- A. 10 mL 0.2 M Ca(OH)₂ + 25 mL 0.1 M HCl
- B. 10 mL 0.01 M H₂SO₄ + 10 mL 0.01 M Ca(OH)₂
- C. 10 mL 0.1 M H₂SO₄ + 10 mL 0.1 M KOH

Choose the correct answer from the options given below:

Options :

6952781211. B < C < A

6952781212. C < A < B

6952781213. C < B < A

6952781214. A < C < B

Question Number : 57 Question Id : 695278357 Question Type : MCQ Option Shuffling : Yes Display Question Number : Yes Is Question Mandatory : No Single Line Question Option : No Option Orientation : Vertical

First order gas phase reaction

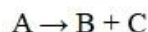

p_i = initial pressure of gas A, p_t = total pressure of the reaction mixture at time t

Expression of rate constant (k) is

Options :

6952781215. $\frac{1}{t} \ln \frac{p_i}{2p_i - p_t}$

6952781216. $\frac{1}{t} \ln \frac{2p_i}{p_i - p_t}$

6952781217. $\frac{1}{t} \ln \frac{p_i}{3p_i - 2p_t}$

6952781218. $\frac{1}{t} \ln \frac{3p_i}{4p_i - p_t}$

Question Number : 58 Question Id : 695278358 Question Type : MCQ Option Shuffling : Yes Display Question Number : Yes Is Question Mandatory : No Single Line Question Option : No Option Orientation : Vertical

Given below are two statements:

Statement I: The correct order of electronegativity of fluorine, oxygen and nitrogen is $F > O > N$.

Statement II: The oxidation state of oxygen in OF_2 is +2 and in Na_2O is -2.

In the light of the above statements, choose the *correct* answer from the options given below

Options :

6952781219. Both Statement I and Statement II are true

6952781220. Both Statement I and Statement II are false

6952781221. Statement I is true but Statement II is false

6952781222. Statement I is false but Statement II is true

Question Number : 59 Question Id : 695278359 Question Type : MCQ Option Shuffling : Yes Display Question Number : Yes Is Question Mandatory : No Single Line Question Option : No Option Orientation : Vertical

Correct statements from the following are:

- A. Nitrogen in oxidation states from +1 to +4 disproportionates in acid medium.
- B. Nitrogen has the ability to form $d\pi - p\pi$ multiple bonds with itself and other elements with small size and high electronegativity.
- C. N-N single bond is stronger than P-P single bond.
- D. Nitrogen has highest density in its group due to small size.
- E. The maximum covalency of nitrogen is four since it has only four valence orbitals for bonding.

Choose the correct answer from the options given below:

Options :

6952781223. B, C and D Only

6952781224. C, D and E Only

6952781225. A, C and E Only

6952781226. A and E Only

Question Number : 60 Question Id : 695278360 Question Type : MCQ Option Shuffling : Yes Display Question Number : Yes Is Question Mandatory : No Single Line Question Option : No Option Orientation : Vertical

Which of the following is **NOT** a physical or chemical characteristics of interstitial compounds?

Options :

6952781227. They have high melting points, higher than those of pure metals.

6952781228. They are very soft and ionic in nature.

6952781229. They retain metallic conductivity.

6952781230. They are chemically inert and usually non-stoichiometric.

Question Number : 61 Question Id : 695278361 Question Type : MCQ Option Shuffling : Yes Display Question Number : Yes Is Question Mandatory : No Single Line Question Option : No Option Orientation : Vertical

The **correct** statements about metal carbonyls are

- A. The metal-carbon bonds in metal carbonyls possess both σ and π -character.
- B. Due to synergic bonding interactions between metal and CO ligand, the metal-carbon bond becomes weak.
- C. The metal-carbon σ bond is formed by the donation of lone pair of electrons on the carbonyl carbon into a vacant orbital of metal.
- D. The metal-carbon π bond is formed by the donation of electrons from filled d-orbital of metal into vacant π^* orbital of CO.

Choose the correct answer from the options given below:

Options :

6952781231. A and B Only

6952781232. A, C and D Only

6952781233. B and C Only

6952781234. A and D Only

Question Number : 62 Question Id : 695278362 Question Type : MCQ Option Shuffling : Yes Display Question Number : Yes Is Question Mandatory : No Single Line Question Option : No Option Orientation : Vertical

Given below are two statements:

Statement I: Each electron in e_g orbitals destabilizes the orbitals by $+0.6 \Delta_o$ and each electron in the t_{2g} orbitals stabilizes the orbitals by $-0.4 \Delta_o$ in an octahedral field on the basis of crystal field theory.

Statement II: All the d - orbitals of the transition metals have the same energy in their free atomic state but when a complex is formed the ligands destroy the degeneracy of these orbitals on the basis of crystal field theory.

In the light of the above statements, choose the **correct** answer from the options given below

Options :

6952781235. Both Statement I and Statement II are correct

6952781236. Both Statement I and Statement II are incorrect

6952781237. Statement I is correct but Statement II is incorrect

6952781238. Statement I is incorrect but Statement II is correct

Question Number : 63 Question Id : 695278363 Question Type : MCQ Option Shuffling : Yes Display Question Number : Yes Is Question Mandatory : No Single Line Question Option : No Option Orientation : Vertical

Given below are two statements:

Statement I: On the basis of inductive effect, the order of stability of alkyl carbanions is $\text{CH}_3^- > \text{CH}_3-\text{CH}_2^- > (\text{CH}_3)_2\text{CH}^- > (\text{CH}_3)_3\text{C}^-$.

Statement II: Allyl and benzyl carbanions are more stabilised by inductive effect and not by resonance effect.

In the light of the above statements, choose the **correct** answer from the options given below

Options :

6952781239. Both Statement I and Statement II are correct
6952781240. Both Statement I and Statement II are incorrect
6952781241. Statement I is correct but Statement II is incorrect
6952781242. Statement I is incorrect but Statement II is correct

Question Number : 64 Question Id : 695278364 Question Type : MCQ Option Shuffling : Yes Display Question Number : Yes Is Question Mandatory : No Single Line Question Option : No Option Orientation : Vertical

"P" is a hydrocarbon of molecular formula:- C_8H_{14} . On ozonolysis, "P" forms "Q". "Q" on treatment with alkali under reflux condition produces "R", which on treatment with I_2/NaOH gives a yellow precipitate. Acidification of the solution gives "S". The structure of "S" is given below:-

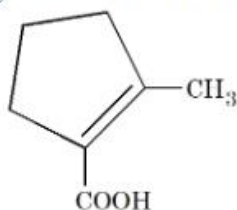

The correct structure of "P" is

Options :

- 6952781243.
- 6952781244.
- 6952781245.

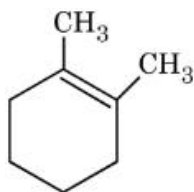

6952781246.

Question Number : 65 Question Id : 695278365 Question Type : MCQ Option Shuffling : Yes Display Question Number : Yes Is Question Mandatory : No Single Line Question Option : No Option Orientation : Vertical

For the following Friedel Craft's alkylation reaction, which of the statements are correct?

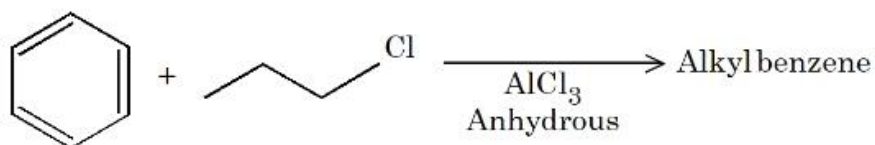

- A. Major product is n-propyl benzene.
- B. iso-propyl carbocation intermediate is also generated.
- C. Multiple substitution is inevitable.
- D. Introducing electron-donating substituent on benzene will not produce any alkyl benzene.

Choose the correct answer from the options given below:

Options :

6952781247. A and D only

6952781248. B and C only

6952781249. A and C only

6952781250. B and D only

Question Number : 66 Question Id : 695278366 Question Type : MCQ Option Shuffling : Yes Display Question Number : Yes Is Question Mandatory : No Single Line Question Option : No Option Orientation : Vertical

Benzyl isocyanide can be obtained from

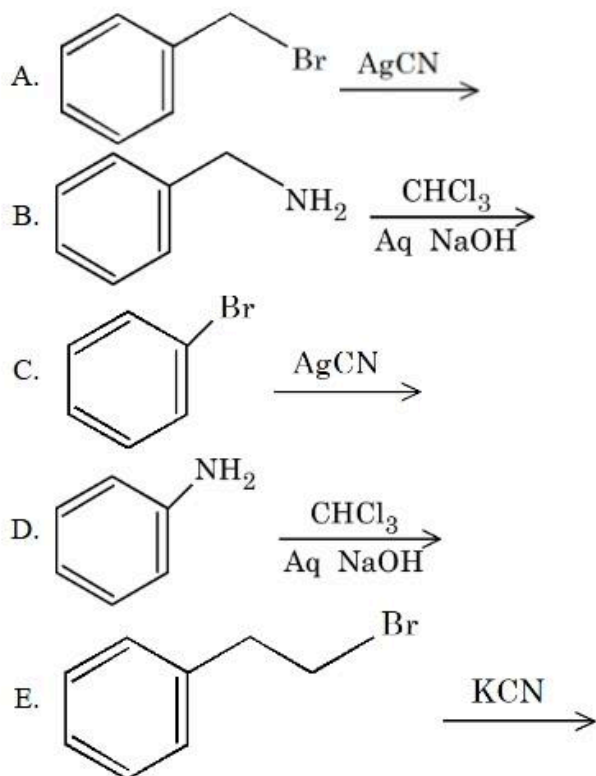

Choose the correct answer from the options given below:

Options :

6952781251. A and B Only

6952781252. A and C Only

6952781253. B and D Only

6952781254. D and E Only

Question Number : 67 Question Id : 695278367 Question Type : MCQ Option Shuffling : Yes Display Question Number : Yes Is Question Mandatory : No Single Line Question Option : No Option Orientation : Vertical

Consider compounds A, B and C with following structural formulae

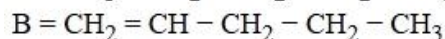
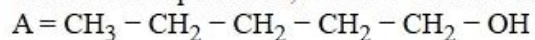

For the conversion of B from A, reagent (D) required is _____ and structural formula of product (E) obtained when C undergoes same reaction using excess reagent (D) is _____.

Options :

6952781255.

| D | E |
|-------------------------------|---|
| Conc. H_2SO_4 | $\text{CH}_2 = \text{CH} - \text{CH}(\text{OH})\text{CH}_3$ |

6952781256.

| D | E |
|-----|---|
| PCC | $\text{HO} - \text{CH}_2 - \text{CH}_2 - \text{CH} = \text{CH}_2$ |

| | | |
|-------------|-----|---|
| | D | E |
| 6952781257. | PCC | $\text{CH}_2 = \text{CH} - \text{CH} = \text{CH}_2$ |

| | | |
|-------------|--|---|
| | D | E |
| 6952781258. | Conc. H_2SO_4 or H_3PO_4 | $\text{CH}_2 = \text{CH} - \text{CH} = \text{CH}_2$ |

Question Number : 68 Question Id : 695278368 Question Type : MCQ Option Shuffling : Yes Display Question Number : Yes Is Question Mandatory : No Single Line Question Option : No Option Orientation : Vertical

Identify the **incorrect** statements.

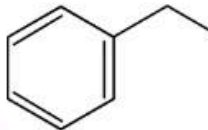
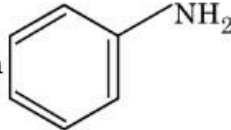
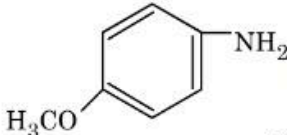
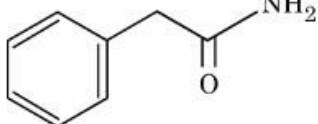
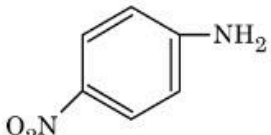
- A.  is a stronger base than 
- B.  can be synthesized by Gabriel phthalimide synthesis.
- C.  $\xrightarrow{\text{Br}_2, \text{NaOH}}$ primary aromatic amine
- D.  $\xrightarrow[\text{(ii) } \Delta]{\text{(i) NaNO}_2, \text{HCl}, 0^\circ\text{C}}$ product will dissolve in NaOH

Choose the correct answer from the options given below:

Options :

6952781259. A and D Only

6952781260. A and C Only

6952781261. B and C Only

6952781262. A and B Only

Question Number : 69 Question Id : 695278369 Question Type : MCQ Option Shuffling : Yes Display Question Number : Yes Is Question Mandatory : No Single Line Question Option : No Option Orientation : Vertical

Identify the **correct** statements.

- A. Glucose exists in two anomeric forms.
- B. Anomers of glucose differ in configuration at C-1 in cyclic hemiacetal structure.
- C. Melting point of α - anomer of glucose is greater than β - anomer.
- D. Specific rotation of α - anomer is $+19^\circ$ while for β - anomer is $+112^\circ$
- E. α and β - anomers of glucose are prepared by crystallization of saturated glucose solution at 303 K and 371 K respectively.

Choose the correct answer from the options given below:

Options :

6952781263. A and B Only

6952781264. B and C Only

6952781265. A, B and D Only

6952781266. A, B and E Only

Question Number : 70 Question Id : 695278370 Question Type : MCQ Option Shuffling : Yes Display Question Number : Yes Is Question Mandatory : No Single Line Question Option : No Option Orientation : Vertical

Given below are two statements:

Statement I: Sodium dichromate and potassium dichromate are classified as primary standards in titrimetric analysis.

Statement II: Phenolphthalein is a weak base, therefore it dissociates in acidic medium.

In the light of the above statements, choose the *correct* answer from the options given below

Options :

6952781267. Both Statement I and Statement II are true

6952781268. Both Statement I and Statement II are false

6952781269. Statement I is true but Statement II is false

6952781270. Statement I is false but Statement II is true

Chemistry Section B

| | |
|---------------------------------------|-----------|
| Section Id : | 69527830 |
| Section Number : | 6 |
| Section type : | Online |
| Mandatory or Optional : | Mandatory |
| Number of Questions : | 5 |
| Number of Questions to be attempted : | 5 |
| Section Marks : | 20 |
| Maximum Instruction Time : | 0 |
| Sub-Section Number : | 1 |
| Sub-Section Id : | 69527830 |
| Question Shuffling Allowed : | Yes |
| Is Section Default? : | No |

Question Number : 71 Question Id : 695278371 Question Type : SA Display Question Number : Yes Keyboard Layout : Inscript

Consider the following species:

BrF_5 , XeF_5^- , BF_4^- , ICl_4^- , XeF_4 , SF_4 , NH_4^+ , ClF_3 , XeF_2 , ICl_2^-

Number of species having sp^3d hybridized central atom is _____.

Response Type : Numeric

Evaluation Required For SA : Yes

Show Word Count : Yes

Answers Type : Equal

Text Areas : PlainText

Possible Answers :

1

Question Number : 72 Question Id : 695278372 Question Type : SA Display Question Number : Yes Keyboard Layout : Inscript

In an estimation of sulphur by Carius method 0.2 g of the substance gave 0.6 g of BaSO_4 . The percentage of sulphur in the substance is _____%.

(Given molar mass in g mol^{-1} S : 32, BaSO_4 : 231)

Response Type : Numeric

Evaluation Required For SA : Yes

Show Word Count : Yes

Answers Type : Equal

Text Areas : PlainText

Possible Answers :

1

Question Number : 73 Question Id : 695278373 Question Type : SA Display Question Number : Yes Keyboard Layout : Inscript

One mole of phenol is treated with dilute HNO_3 at 298 K to give a mixture of products. The mixture is separated by steam distillation. The steam volatile compound (X) is separated. The increase in percentage of oxygen in (X) with respect to phenol is _____ $\times 10^{-1}$ %

(Given molar mass in g mol^{-1} H:1, C:12, N:14, O:16)

Response Type : Numeric

Evaluation Required For SA : Yes

Show Word Count : Yes

Answers Type : Equal

Text Areas : PlainText

Possible Answers :

1

Question Number : 74 Question Id : 695278374 Question Type : SA Display Question Number : Yes Keyboard Layout : Inscript

The values of pressure equilibrium constant recorded at different temperatures for the following equilibrium reaction have been given below

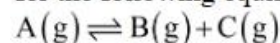

| $\frac{1}{T}(\text{K}^{-1})$ | $\log_{10}K_p$ |
|------------------------------|----------------|
| 0.05 | 3.5 |
| 0.06 | 2.5 |
| 0.07 | 1.5 |

The magnitude of $\frac{\Delta H^\circ}{R}$ calculated from the above data is _____. (Nearest integer)

Response Type : Numeric

Evaluation Required For SA : Yes

Show Word Count : Yes

Answers Type : Equal

Text Areas : PlainText

Possible Answers :

1

Question Number : 75 Question Id : 695278375 Question Type : SA Display Question Number : Yes Keyboard Layout : Inscript

If the half life of a first order reaction is 6.93 minutes then the time required for completion of 99% of the reaction will be _____ minutes .
(Given : $\log 2 = 0.3010$)

Response Type : Numeric

Evaluation Required For SA : Yes

Show Word Count : Yes

Answers Type : Equal

Text Areas : PlainText

Possible Answers :

1