

National Testing Agency

| | |
|-----------------------|-----------------------------|
| Question Paper Name : | B Tech 5th Apr 2026 Shift 2 |
| Subject Name : | B. Tech |
| Creation Date : | 2026-04-05 19:23:59 |
| Duration : | 180 |
| Total Marks : | 300 |
| Display Marks: | Yes |

B. Tech

| | |
|--------------------------|---------|
| Group Number : | 1 |
| Group Id : | 6911217 |
| Group Maximum Duration : | 0 |
| Group Minimum Duration : | 180 |
| Show Attended Group? : | No |
| Edit Attended Group? : | No |
| Break time : | 0 |
| Group Marks : | 300 |

Mathematics Section A

| | |
|---------------------------------------|-----------|
| Section Id : | 69112137 |
| Section Number : | 1 |
| Section type : | Online |
| Mandatory or Optional : | Mandatory |
| Number of Questions : | 20 |
| Number of Questions to be attempted : | 20 |
| Section Marks : | 80 |
| Maximum Instruction Time : | 0 |
| Sub-Section Number : | 1 |
| Sub-Section Id : | 69112137 |
| Question Shuffling Allowed : | Yes |
| Is Section Default? : | No |

Question Number : 1 Question Id : 691121451 Question Type : MCQ Option Shuffling : Yes Display Question Number : Yes Is Question Mandatory : No Single Line Question Option : No Option Orientation : Vertical

Let α, β be the roots of the equation $x^2 - x + p = 0$ and γ, δ be the roots the equation $x^2 - 4x + q = 0$; $p, q \in \mathbb{Z}$. If $\alpha, \beta, \gamma, \delta$ are in G.P., then $|p + q|$ equals :

Options :

6911211531. 16

6911211532. 32

6911211533. 34

6911211534. 38

Question Number : 2 Question Id : 691121452 Question Type : MCQ Option Shuffling : Yes Display Question Number : Yes Is Question Mandatory : No Single Line Question Option : No Option Orientation : Vertical

Let $z_1, z_2 \in \mathbb{C}$ be the distinct solutions of the equation $z^2 + 4z - (1 + 12i) = 0$.

Then $|z_1|^2 + |z_2|^2$ is equal to :

Options :

6911211535. 18

6911211536. 22

6911211537. 29

6911211538. 34

Question Number : 3 Question Id : 691121453 Question Type : MCQ Option Shuffling : Yes Display Question Number : Yes Is Question Mandatory : No Single Line Question Option : No Option Orientation : Vertical

If $f: \mathbb{N} \rightarrow \mathbb{Z}$ is defined by

$$f(n) = \begin{vmatrix} n & -1 & -5 \\ -2n^2 & 3(2k+1) & 2k+1 \\ -3n^3 & 3k(2k+1) & 3k(k+2)+1 \end{vmatrix}, k \in \mathbb{N},$$

and $\sum_{n=1}^k f(n) = 98$, then k is equal to :

Options :

6911211539. 3

6911211540. 4

6911211541. 5

6911211542. 6

Question Number : 4 Question Id : 691121454 Question Type : MCQ Option Shuffling : Yes Display Question Number : Yes Is Question Mandatory : No Single Line Question Option : No Option Orientation : Vertical

Let M be a 3×3 matrix such that

$$M \begin{pmatrix} 1 \\ 0 \\ 0 \end{pmatrix} = \begin{pmatrix} 1 \\ 2 \\ 3 \end{pmatrix}, M \begin{pmatrix} 0 \\ 1 \\ 0 \end{pmatrix} = \begin{pmatrix} 0 \\ 1 \\ 2 \end{pmatrix} \text{ and } M \begin{pmatrix} 0 \\ 0 \\ 1 \end{pmatrix} = \begin{pmatrix} -1 \\ 1 \\ 1 \end{pmatrix}. \text{ If } M \begin{pmatrix} x \\ y \\ z \end{pmatrix} = \begin{pmatrix} 1 \\ 7 \\ 11 \end{pmatrix}, \text{ then } x + y + z \text{ equals :}$$

Options :

6911211543. 4

6911211544. 5

6911211545. 7

6911211546. 11

Question Number : 5 Question Id : 691121455 Question Type : MCQ Option Shuffling : Yes Display Question Number : Yes Is Question Mandatory : No Single Line Question Option : No Option Orientation : Vertical

If the sum of the first 10 terms of the series $\frac{1}{1+1^4 \times 4} + \frac{2}{1+2^4 \times 4} + \frac{3}{1+3^4 \times 4} + \frac{4}{1+4^4 \times 4} + \dots$

is $\frac{m}{n}$, gcd (m, n) = 1, then m + n is equal to :

Options :

6911211547. 256

6911211548. 264

6911211549. 276

6911211550. 284

Question Number : 6 Question Id : 691121456 Question Type : MCQ Option Shuffling : Yes Display Question Number : Yes Is Question Mandatory : No Single Line Question Option : No Option Orientation : Vertical

Let $A_1, A_2, A_3, \dots, A_{39}$ be 39 arithmetic means between the numbers 59 and 159. Then the mean of A_{25}, A_{28}, A_{31} and A_{36} is equal to :

Options :

6911211551. 129

6911211552. 136

6911211553. 131.50

6911211554. 134

Question Number : 7 Question Id : 691121457 Question Type : MCQ Option Shuffling : Yes Display Question Number : Yes Is Question Mandatory : No Single Line Question Option : No Option Orientation : Vertical

The coefficient of x^2 in the expansion of $\left(2x^2 + \frac{1}{x}\right)^{10}$, $x \neq 0$, is :

Options :

6911211555. 3240

6911211556. 3360

6911211557. 3480

6911211558. 3600

Question Number : 8 Question Id : 691121458 Question Type : MCQ Option Shuffling : Yes Display Question Number : Yes Is Question Mandatory : No Single Line Question Option : No Option Orientation : Vertical

The probabilities that players A and B of a team are selected for the captaincy for a tournament are 0.6 and 0.4, respectively. If A is selected the captain, the probability that the team wins the tournament is 0.8 and if B is selected the captain, the probability that the team wins the tournament is 0.7. Then the probability, that the team wins the tournament, is :

Options :

6911211559. 0.74

6911211560. 0.76

6911211561. 0.72

6911211562. 0.78

Question Number : 9 Question Id : 691121459 Question Type : MCQ Option Shuffling : Yes Display Question Number : Yes Is Question Mandatory : No Single Line Question Option : No Option Orientation : Vertical

A box contains 5 blue, 6 yellow and 4 red balls. The number of ways, of drawing 8 balls containing at least two balls of each colour, is :

Options :

6911211563. 4100

6911211564. 4140

6911211565. 4230

6911211566. 4290

Question Number : 10 Question Id : 691121460 Question Type : MCQ Option Shuffling : Yes Display Question Number : Yes Is Question Mandatory : No Single Line Question Option : No Option Orientation : Vertical

A variable X takes values 0, 0, 2, 6, 12, 20, ..., $n(n-1)$ with frequencies ${}^nC_0, {}^nC_1, {}^nC_2, {}^nC_3, {}^nC_4, {}^nC_5, \dots, {}^nC_n$, respectively. If the mean of this data is 60, then its median is :

Options :

6911211567. 56

6911211568. 42

6911211569. 72

6911211570. 90

Question Number : 11 Question Id : 691121461 Question Type : MCQ Option Shuffling : Yes Display Question Number : Yes Is Question Mandatory : No Single Line Question Option : No Option Orientation : Vertical

Let the point P be the vertex of the parabola $y = x^2 - 6x + 12$. If a line passing through the point P intersects the circle $x^2 + y^2 - 2x - 4y + 3 = 0$ at the points R and S, then the maximum value of $(PR + PS)^2$ is :

Options :

6911211571. 10

6911211572. 20

6911211573. 25

6911211574. 5

Question Number : 12 Question Id : 691121462 Question Type : MCQ Option Shuffling : Yes Display Question Number : Yes Is Question Mandatory : No Single Line Question Option : No Option Orientation : Vertical

Let the directrix of the parabola $P : y^2 = 8x$, cut x -axis at the point A. Let $B (\alpha, \beta)$, $\alpha > 1$, be a point on P such that the slope of AB is $3/5$. If BC is a focal chord of P, then six times the area of ΔABC is :

Options :

6911211575. 80

6911211576. 160

6911211577. 174

6911211578. 192

Question Number : 13 Question Id : 691121463 Question Type : MCQ Option Shuffling : Yes Display Question Number : Yes Is Question Mandatory : No Single Line Question Option : No Option Orientation : Vertical

Let the eccentricity e of a hyperbola satisfy the equation $6e^2 - 11e + 3 = 0$. If the foci of the hyperbola are $(3, 5)$ and $(3, -4)$, then the length of its latus rectum is :

Options :

6911211579. $\frac{11}{3}$

6911211580. $\frac{17}{3}$

6911211581. $\frac{15}{2}$

6911211582. $\frac{17}{2}$

Question Number : 14 Question Id : 691121464 Question Type : MCQ Option Shuffling : Yes Display Question Number : Yes Is Question Mandatory : No Single Line Question Option : No Option Orientation : Vertical

Let a triangle PQR be such that P and Q lie on the line $\frac{x+3}{8} = \frac{y-4}{2} = \frac{z+1}{2}$ and are at a distance of 6 units from R (1, 2, 3). If (α, β, γ) is the centroid of ΔPQR , then $\alpha + \beta + \gamma$ is equal to :

Options :

6911211583. 4

6911211584. 5

6911211585. 6

6911211586. 8

Question Number : 15 Question Id : 691121465 Question Type : MCQ Option Shuffling : Yes Display Question Number : Yes Is Question Mandatory : No Single Line Question Option : No Option Orientation : Vertical

If the distance of the point (a, 2, 5) from the image of the point (1, 2, 7) in the line $\frac{x}{1} = \frac{y-1}{1} = \frac{z-2}{2}$ is 4, then the sum of all possible values of a is equal to :

Options :

6911211587. 11

6911211588. 9

6911211589. 6

6911211590. 4

Question Number : 16 Question Id : 691121466 Question Type : MCQ Option Shuffling : Yes Display Question Number : Yes Is Question Mandatory : No Single Line Question Option : No Option Orientation : Vertical

Let O be the origin, $\vec{OP} = \vec{a}$ and $\vec{OQ} = \vec{b}$. If R is the point on \vec{OP} such that $\vec{OP} = 5\vec{OR}$, and M is the point such that $\vec{OQ} = 5\vec{RM}$, then \vec{PM} is equal to :

Options :

6911211591. $\frac{1}{5}(\vec{a} - 4\vec{b})$

6911211592. $\frac{1}{5}(\vec{b} - 4\vec{a})$

6911211593. $\frac{1}{5}(-\vec{a} + 4\vec{b})$

6911211594. $\frac{1}{5}(-\vec{b} + 4\vec{a})$

Question Number : 17 Question Id : 691121467 Question Type : MCQ Option Shuffling : Yes Display Question Number : Yes Is Question Mandatory : No Single Line Question Option : No Option Orientation : Vertical

Let $f(x) = \lim_{y \rightarrow 0} \frac{(1 - \cos(xy)) \tan(xy)}{y^3}$. Then the number of solutions of the equation $f(x) = \sin x$,

$x \in \mathbf{R}$ is :

Options :

6911211595. 0

6911211596. 2

6911211597. 3

6911211598. 1

Question Number : 18 Question Id : 691121468 Question Type : MCQ Option Shuffling : Yes Display Question Number : Yes Is Question Mandatory : No Single Line Question Option : No Option Orientation : Vertical

Let $(2^{1-a} + 2^{1+a}), f(a), (3^a + 3^{-a})$ be in A.P. and α be the minimum value of $f(a)$. Then the value of

the integral $\int_{\log_e(\alpha-1)}^{\log_e(\alpha)} \frac{dx}{(e^{2x} - e^{-2x})}$ is :

Options :

6911211599. $\frac{1}{2} \log_e\left(\frac{4}{3}\right)$

6911211600. $\frac{1}{4} \log_e\left(\frac{4}{3}\right)$

6911211601. $\frac{1}{2} \log_e\left(\frac{8}{5}\right)$

6911211602. $\frac{1}{4} \log_e\left(\frac{8}{5}\right)$

Question Number : 19 Question Id : 691121469 Question Type : MCQ Option Shuffling : Yes Display Question Number : Yes Is Question Mandatory : No Single Line Question Option : No Option Orientation : Vertical

Let $f : [1, \infty) \rightarrow \mathbf{R}$ be a differentiable function defined as $f(x) = \int_1^x f(t)dt + (1-x)(\log_e x - 1) + e$.

Then the value of $f(f(1))$ is :

Options :

6911211603. $(1 + e^e)$

6911211604. $(1 + e)$

6911211605. $(1 + e + e^e)$

6911211606. $1 + 2e$

Question Number : 20 Question Id : 691121470 Question Type : MCQ Option Shuffling : Yes Display Question Number : Yes Is Question Mandatory : No Single Line Question Option : No Option Orientation : Vertical

Let $f(x)$ and $g(x)$ be twice differentiable functions satisfying $f''(x) = g''(x)$ for all $x \in \mathbf{R}$, $f'(1) = 2g'(1) = 4$ and $g(2) = 3f(2) = 9$. Then $f(25) - g(25)$ is equal to :

Options :

6911211607. 20

6911211608. 40

6911211609. -20

6911211610. -40

Mathematics Section B

| | |
|---------------------------------------|-----------|
| Section Id : | 69112138 |
| Section Number : | 2 |
| Section type : | Online |
| Mandatory or Optional : | Mandatory |
| Number of Questions : | 5 |
| Number of Questions to be attempted : | 5 |
| Section Marks : | 20 |
| Maximum Instruction Time : | 0 |
| Sub-Section Number : | 1 |
| Sub-Section Id : | 69112138 |
| Question Shuffling Allowed : | Yes |
| Is Section Default? : | No |

Question Number : 21 Question Id : 691121471 Question Type : SA Display Question Number : Yes Keyboard Layout : Inscript

Let $A = \{1, 4, 7\}$ and $B = \{2, 3, 8\}$. Then the number of elements, in the relation $R = \{((a_1, b_1), (a_2, b_2)) \in ((A \times B) \times (A \times B)) : a_1 + b_2 \text{ divides } a_2 + b_1\}$ is _____.

Response Type : Numeric
Evaluation Required For SA : Yes
Show Word Count : Yes
Answers Type : Equal
Text Areas : PlainText
Possible Answers :

1

Question Number : 22 Question Id : 691121472 Question Type : SA Display Question Number : Yes Keyboard Layout : Inscript

From the point $(-1, -1)$, two rays are sent making angles of 45° with the line $x + y = 0$. These rays get reflected from the mirror $x + 2y = 1$. If the equations of the reflected rays are $ax + by = 9$ and $cx + dy = 7$, $a, b, c, d \in \mathbf{Z}$, then the value of $ad + bc$ is _____.

Response Type : Numeric
Evaluation Required For SA : Yes
Show Word Count : Yes
Answers Type : Equal
Text Areas : PlainText
Possible Answers :

1

Question Number : 23 Question Id : 691121473 Question Type : SA Display Question Number : Yes Keyboard Layout : Inscript

If $S = \left\{ \theta \in [-\pi, \pi] : \cos \theta \cos \frac{5\theta}{2} = \cos 7\theta \cos \frac{7\theta}{2} \right\}$, then $n(S)$ is equal to _____.

Response Type : Numeric
Evaluation Required For SA : Yes
Show Word Count : Yes
Answers Type : Equal
Text Areas : PlainText
Possible Answers :

1

Question Number : 24 Question Id : 691121474 Question Type : SA Display Question Number : Yes Keyboard Layout : Inscript

Let $f: \mathbf{R} \rightarrow \mathbf{R}$ be a function such that $f(x) + 3f\left(\frac{\pi}{2} - x\right) = \sin x$, $x \in \mathbf{R}$. Let the maximum value of f on \mathbf{R} be α . If the area of the region bounded by the curves $g(x) = x^2$ and $h(x) = \beta x^3$, $\beta > 0$, is α^2 , then $30\beta^3$ is equal to _____.

Response Type : Numeric
Evaluation Required For SA : Yes
Show Word Count : Yes
Answers Type : Equal
Text Areas : PlainText
Possible Answers :

1

Question Number : 25 Question Id : 691121475 Question Type : SA Display Question Number : Yes Keyboard Layout : Inscript

Let $y = y(x)$ be the solution of the differential equation

$(\tan x)^{1/2} dy = (\sec^3 x - (\tan x)^{3/2} y) dx$, $0 < x < \frac{\pi}{2}$, $y\left(\frac{\pi}{4}\right) = \frac{6\sqrt{2}}{5}$. If $y\left(\frac{\pi}{3}\right) = \frac{4}{5} \alpha$, then α^4 equals

_____.

Response Type : Numeric
Evaluation Required For SA : Yes
Show Word Count : Yes

Answers Type : Equal

Text Areas : PlainText

Possible Answers :

1

Physics Section A

| | |
|---------------------------------------|-----------|
| Section Id : | 69112139 |
| Section Number : | 3 |
| Section type : | Online |
| Mandatory or Optional : | Mandatory |
| Number of Questions : | 20 |
| Number of Questions to be attempted : | 20 |
| Section Marks : | 80 |
| Maximum Instruction Time : | 0 |
| Sub-Section Number : | 1 |
| Sub-Section Id : | 69112139 |
| Question Shuffling Allowed : | Yes |
| Is Section Default? : | No |

Question Number : 26 Question Id : 691121476 Question Type : MCQ Option Shuffling : Yes Display Question Number : Yes Is Question Mandatory : No Single Line Question Option : No Option Orientation : Vertical

Match List - I with List - II.

List - I

List - II

A. Meter (L)

I. $\sqrt{\frac{hc}{G}}$

B. Second (S)

II. $\sqrt{\frac{Gh}{c^5}}$

C. Kilogram (M)

III. $\sqrt{\frac{K^2 L^2 c^3}{Gh}}$

D. Kelvin (K)

IV. $\sqrt{\frac{Gh}{c^3}}$

where h (Planck's constant), G (gravitational constant) and c (speed of light in vacuum) as fundamental units.

Choose the **correct** answer from the options given below :

Options :

6911211616. A-II, B-IV, C-I, D-III

6911211617. A-IV, B-II, C-I, D-III

6911211618. A-IV, B-I, C-II, D-III

6911211619. A-III, B-I, C-II, D-IV

Question Number : 27 Question Id : 691121477 Question Type : MCQ Option Shuffling : Yes Display Question Number : Yes Is Question Mandatory : No Single Line Question Option : No Option Orientation : Vertical

In an experiment to determine the resistance of a given wire using Ohm's law, the voltmeter and ammeter readings are noted as 10 V and 5 A, respectively. The least counts of voltmeter and ammeter are 500 mV and 200 mA, respectively. The estimated error in the resistance measurement is _____ Ω

Options :

- 6911211620. 0.25
- 6911211621. 2
- 6911211622. 2.5
- 6911211623. 0.18

Question Number : 28 Question Id : 691121478 Question Type : MCQ Option Shuffling : Yes Display Question Number : Yes Is Question Mandatory : No Single Line Question Option : No Option Orientation : Vertical

A mass of 1 kg is kept on a inclined plane with 30° inclination with respect to horizontal plane and it is at rest initially. Then the whole assembly is moved up with constant velocity of 4 m/s. The work done by the frictional force in time 2 s is _____ J. (Take $g = 10 \text{ m/s}^2$)

Options :

- 6911211624. 20
- 6911211625. 25
- 6911211626. 30
- 6911211627. 10

Question Number : 29 Question Id : 691121479 Question Type : MCQ Option Shuffling : Yes Display Question Number : Yes Is Question Mandatory : No Single Line Question Option : No Option Orientation : Vertical

The velocity (v) versus time (t) plot of a particle is shown in the figure, for a time interval of 40 s. The total distance travelled by the particle and the average velocity during this period are, respectively _____.

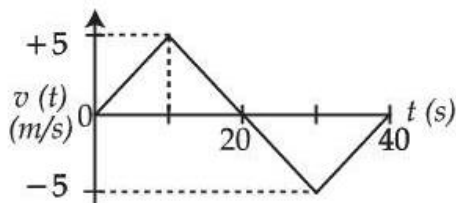

Options :

- 6911211628. 25 m and zero
- 6911211629. 50 m and zero

6911211630. 100 m and zero

6911211631. 100 m and 2.5 m/s

Question Number : 30 Question Id : 691121480 Question Type : MCQ Option Shuffling : Yes Display Question Number : Yes Is Question Mandatory : No Single Line Question Option : No Option Orientation : Vertical

A wheel initially at rest is subjected to a uniform angular acceleration about its axis. In the first 2 s it rotates through an angle θ_1 and in the next 2 s it rotates through an angle θ_2 . The ratio $\frac{\theta_2}{\theta_1}$ is _____.

Options :

6911211632. 6

6911211633. 3

6911211634. 4

6911211635. $\frac{1}{3}$

Question Number : 31 Question Id : 691121481 Question Type : MCQ Option Shuffling : Yes Display Question Number : Yes Is Question Mandatory : No Single Line Question Option : No Option Orientation : Vertical

An object of uniform density rolls up the curved path with the initial velocity v_0 as shown in the figure. If the maximum height attained by an object is $\frac{7v_0^2}{10g}$ (g = acceleration due to gravity), the object is a _____.

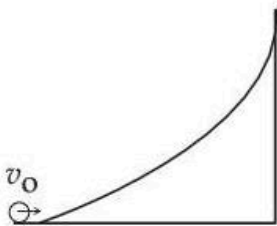

Options :

6911211636. solid cylinder

6911211637. ring

6911211638. disc

6911211639. solid sphere

Question Number : 32 Question Id : 691121482 Question Type : MCQ Option Shuffling : Yes Display Question Number : Yes Is Question Mandatory : No Single Line Question Option : No Option Orientation : Vertical

A body of mass m is taken from the surface of earth to a height equal to twice the radius of earth (R_e). The increase in potential energy will be _____.

(g is acceleration due to gravity at the surface of earth)

Options :

6911211640. $\frac{1}{2} mgR_e$

6911211641. $\frac{3}{4} mgR_e$

6911211642. $\frac{1}{4} mgR_e$

6911211643. $\frac{2}{3} mgR_e$

Question Number : 33 Question Id : 691121483 Question Type : MCQ Option Shuffling : Yes Display Question Number : Yes Is Question Mandatory : No Single Line Question Option : No Option Orientation : Vertical

Eight mercury drops, each of radius r , coalesce to form a bigger drop. The surface energy released in this process is _____. (S is the surface tension of mercury).

Options :

6911211644. $8 \pi r^2 S$

6911211645. $16 \pi r^2 S$

6911211646. $64 \pi r^2 S$

6911211647. $4 \pi r^2 S$

Question Number : 34 Question Id : 691121484 Question Type : MCQ Option Shuffling : Yes Display Question Number : Yes Is Question Mandatory : No Single Line Question Option : No Option Orientation : Vertical

An ideal gas at pressure P and temperature T is expanding such that $PT^3 = \text{constant}$. The coefficient of volume expansion of the gas is _____.

Options :

6911211648. $\frac{2}{T}$

6911211649. $\frac{1}{T}$

6911211650. $\frac{4}{T}$

6911211651. $\frac{3}{T}$

Question Number : 35 Question Id : 691121485 Question Type : MCQ Option Shuffling : Yes Display Question Number : Yes Is Question Mandatory : No Single Line Question Option : No Option Orientation : Vertical

Match List - I with List - II.

List - I

List - II

A. $\sin^2 \omega t$

I. Periodic with time period $T = \frac{\pi}{\omega}$ but not simple harmonic motion (SHM)

B. $\sin^3(2\omega t)$

II. Periodic with time period $T = \frac{2\pi}{\omega}$ but Not SHM

C. $\sin(\omega t) + \cos(\pi\omega t)$

III. Periodic with time period $T = \frac{\pi}{\omega}$ and SHM

D. $\cos \omega t + \cos 2\omega t$

IV. Non-periodic

Choose the **correct** answer from the options given below :

Options :

6911211652. A-III, B-I, C-IV, D-II

6911211653. A-II, B-I, C-III, D-IV

6911211654. A-III, B-II, C-IV, D-I

6911211655. A-II, B-I, C-IV, D-III

Question Number : 36 Question Id : 691121486 Question Type : MCQ Option Shuffling : Yes Display Question Number : Yes Is Question Mandatory : No Single Line Question Option : No Option Orientation : Vertical

A metal rod of length L rotates about one end at origin with a uniform angular velocity ω . The magnetic field radially falls off as $B(r) = B_0 e^{-\lambda r}$; λ being a positive constant. The emf induced (neglecting the centripetal force on electrons in the rod) is :

Options :

6911211656. $B_0 \omega \left[\frac{1}{\lambda^2} - e^{-\lambda L} \left(\frac{1}{\lambda^2} + \frac{L}{\lambda} \right) \right]$

6911211657. $B_0 \omega \left[\frac{1}{\lambda^2} + e^{-\lambda L} \left(\frac{1}{\lambda^2} + \frac{L}{\lambda} \right) \right]$

6911211658. $B_0 \omega \left[\frac{4}{\lambda^2} - e^{-2\lambda L} \left(\frac{1}{\lambda^2} + \frac{2L}{\lambda} \right) \right]$

6911211659. $B_0 \omega \left[\frac{3}{\lambda^2} - e^{-3\lambda L} \left(\frac{3}{\lambda^2} + \frac{L}{\lambda} \right) \right]$

Question Number : 37 Question Id : 691121487 Question Type : MCQ Option Shuffling : Yes Display Question Number : Yes Is Question Mandatory : No Single Line Question Option : No Option Orientation : Vertical

Under steady state condition the potential difference across the capacitor in the circuit is _____ V.

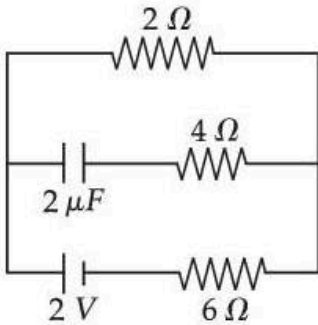

Options :

6911211660. 0.5

6911211661. 1.5

6911211662. 0

6911211663. 2

Question Number : 38 Question Id : 691121488 Question Type : MCQ Option Shuffling : Yes Display Question Number : Yes Is Question Mandatory : No Single Line Question Option : No Option Orientation : Vertical

A particle of charge q and mass m is projected from origin with an initial velocity

$\vec{v} = \left(\frac{v_0}{\sqrt{2}} \hat{x} + \frac{v_0}{\sqrt{2}} \hat{y} \right)$. There exists a uniform magnetic field $\vec{B} = B_0 \hat{z}$ and a space varying electric

field $\vec{E} = E_0 e^{-\lambda x} \hat{x}$ within the region $0 \leq x \leq L$. After travelling a distance such that x -coordinate has changed from $x=0$ to $x=L$, the change in the kinetic energy is _____.

Options :

6911211664. $\frac{q E_0}{\lambda} [1 - e^{-\lambda L}]$

6911211665. $\left(\frac{v_0 q B_0}{2\lambda} \right) [2 - e^{-2\lambda L}]$

6911211666. $\frac{q E_0}{\lambda} [1 + e^{-\lambda L}]$

6911211667. $q \left(\frac{E_0 + v_0 B_0}{\lambda} \right) [1 - e^{-\lambda L/2}]$

Question Number : 39 Question Id : 691121489 Question Type : MCQ Option Shuffling : Yes Display Question Number : Yes Is Question Mandatory : No Single Line Question Option : No Option Orientation : Vertical

Given below are two statements : one is labelled as **Assertion (A)** and the other is labelled as **Reason (R)**.

Assertion (A) : The electromagnetic wave exerts pressure on the surface on which they are allowed to fall.

Reason (R) : There is no mass associated with the electromagnetic waves.

In the light of the above statements, choose the **correct answer** from the options given below :

Options :

6911211668. Both **(A)** and **(R)** are true and **(R)** is the correct explanation of **(A)**

6911211669. Both **(A)** and **(R)** are true but **(R)** is **not** the correct explanation of **(A)**

6911211670. **(A)** is true but **(R)** is false

6911211671. **(A)** is false but **(R)** is true

Question Number : 40 Question Id : 691121490 Question Type : MCQ Option Shuffling : Yes Display Question Number : Yes Is Question Mandatory : No Single Line Question Option : No Option Orientation : Vertical

A thin convex lens and a thin concave lens are kept in contact and are co-axial. Which of the following statements is correct for this combination of two lenses ?

Options :

6911211672. behaves as concave lens if $|f_{\text{convex}}| > |f_{\text{concave}}|$

6911211673. behaves as concave lens if $|f_{\text{convex}}| < |f_{\text{concave}}|$

6911211674. behaves as convex lens if $|f_{\text{convex}}| > |f_{\text{concave}}|$

6911211675.

Focal length of the lens system will change if the positions of two lenses are interchanged

Question Number : 41 Question Id : 691121491 Question Type : MCQ Option Shuffling : Yes Display Question Number : Yes Is Question Mandatory : No Single Line Question Option : No Option Orientation : Vertical

An object AB is placed 15 cm on the left of a convex lens P of focal length 10 cm. Another convex lens Q is now placed 15 cm right of lens P . If the focal length of lens Q is 15 cm, the final image is _____.

Options :

6911211676. virtual, formed at 7.5 cm right of lens Q , with a size bigger than that of AB

6911211677. real, formed at 7.5 cm right of lens Q , with a size same as that of AB

6911211678. formed at infinity.

6911211679. real, formed at 7 cm right of lens Q , with a size smaller than that of AB

Question Number : 42 Question Id : 691121492 Question Type : MCQ Option Shuffling : Yes Display Question Number : Yes Is Question Mandatory : No Single Line Question Option : No Option Orientation : Vertical

The maximum intensity in a Young's double slit experiment is I_0 . Distance between the slits (d) is 5λ , where λ is the wavelength of light used. The intensity of the fringe, exactly opposite to one of the slits on the screen, placed at $D = 10d$ is _____.

Options :

6911211680. $\frac{I_0}{4}$

6911211681. $\frac{I_0}{2}$

6911211682. I_0

6911211683. $\frac{3I_0}{4}$

Question Number : 43 Question Id : 691121493 Question Type : MCQ Option Shuffling : Yes Display Question Number : Yes Is Question Mandatory : No Single Line Question Option : No Option Orientation : Vertical

An electron is travelling with a velocity v in free space and when it enters a medium, its velocity is reduced by 20%. The de Broglie wavelength of electron in the medium is $\alpha\lambda_0$, where λ_0 is its de Broglie wavelength in free space. The value of α is _____.

Options :

6911211684. 1.20

6911211685. 1.0

6911211686. 1.25

6911211687. 0.75

Question Number : 44 Question Id : 691121494 Question Type : MCQ Option Shuffling : Yes Display Question Number : Yes Is Question Mandatory : No Single Line Question Option : No Option Orientation : Vertical

Assuming the experimental mass of $^{12}_6\text{C}$ as 12 u, the mass defect of $^{12}_6\text{C}$ atom is _____ MeV/c².

(Mass of proton = 1.00727 u. mass of neutron = 1.00866 u, 1 u = 931.5 MeV/c² and c is the speed of the light in vacuum).

Options :

6911211688. 127.5

6911211689. 89.03

6911211690. 272.0

6911211691. 92.0

Question Number : 45 Question Id : 691121495 Question Type : MCQ Option Shuffling : Yes Display Question Number : Yes Is Question Mandatory : No Single Line Question Option : No Option Orientation : Vertical

In a semiconductor p-n diode, the doping concentrations on p-side and n-side are 10^{15} atoms/cm³ and 10^{18} atoms/cm³, respectively. Which one of the following statements is true ?

Options :

6911211692. Widths of depletion region on either side of the interface are equal

6911211693. The depletion region width is more on p-side compared to that in n-side

6911211694. The depletion region width is more on n-side compared to that in p-side

6911211695. No depletion region forms because of unequal doping concentrations on p and n-sides

Physics Section B

| | |
|---------------------------------------|-----------|
| Section Id : | 69112140 |
| Section Number : | 4 |
| Section type : | Online |
| Mandatory or Optional : | Mandatory |
| Number of Questions : | 5 |
| Number of Questions to be attempted : | 5 |
| Section Marks : | 20 |
| Maximum Instruction Time : | 0 |
| Sub-Section Number : | 1 |
| Sub-Section Id : | 69112140 |
| Question Shuffling Allowed : | Yes |
| Is Section Default? : | No |

Question Number : 46 Question Id : 691121496 Question Type : SA Display Question Number : Yes Keyboard Layout : Inscript

A copper wire of length 3 m is stretched by 3 mm by applying an external force. The volume of the wire is $600 \times 10^{-6} \text{ m}^3$. The elastic potential energy stored in the wire in stretched condition would be _____ J.

(Given Young modulus of copper = $1.1 \times 10^{11} \text{ N/m}^2$)

Response Type : Numeric

Evaluation Required For SA : Yes

Show Word Count : Yes

Answers Type : Equal

Text Areas : PlainText

Possible Answers :

1

Question Number : 47 Question Id : 691121497 Question Type : SA Display Question Number : Yes Keyboard Layout : Inscript

The heat extracted out of x gram of water initially at 50°C to cool it down to 0°C is sufficient to evaporate $(1000 - x)$ gram of water also initially at 50°C . The value of x (closest integer) is _____.

(Take latent heat of water 2256 kJ/kg , K , specific heat capacity of water $4200 \text{ J/kg} \cdot K$)

Response Type : Numeric

Evaluation Required For SA : Yes

Show Word Count : Yes

Answers Type : Equal

Text Areas : PlainText

Possible Answers :

1

Question Number : 48 Question Id : 691121498 Question Type : SA Display Question Number : Yes Keyboard Layout : Inscript

A series LCR circuit with $R = 20 \Omega$, $L = 1.6 \text{ H}$ and $C = 40 \mu\text{F}$ is connected to a variable frequency a.c. source. The inductive reactance at resonant frequency is _____ Ω .

Response Type : Numeric

Evaluation Required For SA : Yes

Show Word Count : Yes

Answers Type : Equal

Text Areas : PlainText

Possible Answers :

1

Question Number : 49 Question Id : 691121499 Question Type : SA Display Question Number : Yes Keyboard Layout : Inscript

When an external resistance of 5Ω is connected across terminals of a cell, a current of 0.25 A flows through it. When the 5Ω resistor is replaced by a 2Ω resistor, a current of 0.5 A flows through it. The internal resistance of the cell is _____ Ω .

Response Type : Numeric

Evaluation Required For SA : Yes

Show Word Count : Yes

Answers Type : Equal

Text Areas : PlainText

Possible Answers :

1

Question Number : 50 Question Id : 691121500 Question Type : SA Display Question Number : Yes Keyboard Layout : Inscript

A circular loop of radius 20 cm and resistance 2Ω is placed in a time varying magnetic field $\vec{B} = (2t^2 + 2t + 3) \text{ T}$. At $t=0$, for the plane of the loop being perpendicular to the magnetic field and, the induced current in the loop at $t=3 \text{ s}$ is $\frac{\alpha}{50} \text{ A}$. The value of α is _____.

(Take $\pi = 22/7$)

Response Type : Numeric

Evaluation Required For SA : Yes

Show Word Count : Yes

Answers Type : Equal

Text Areas : PlainText

Possible Answers :

1

Chemistry Section A

| | |
|--|-----------|
| Section Id : | 69112141 |
| Section Number : | 5 |
| Section type : | Online |
| Mandatory or Optional : | Mandatory |
| Number of Questions : | 20 |
| Number of Questions to be attempted : | 20 |
| Section Marks : | 80 |
| Maximum Instruction Time : | 0 |
| Sub-Section Number : | 1 |
| Sub-Section Id : | 69112141 |
| Question Shuffling Allowed : | Yes |
| Is Section Default? : | No |

Question Number : 51 Question Id : 691121501 Question Type : MCQ Option Shuffling : Yes Display Question Number : Yes Is Question Mandatory : No Single Line Question Option : No Option Orientation : Vertical

What volume of hydrogen gas at STP would be liberated by action of 50 mL of H_2SO_4 of 50% purity (density = 1.3 g mL^{-1}) on 20 g of zinc ?

Given : Molar mass of H, O, S, Zn are 1, 16, 32, 65 g mol^{-1} respectively.

Options :

6911211701. 5.824 L

6911211702. 7.428 L

6911211703. 6.892 L

6911211704. 8.375 L

Question Number : 52 Question Id : 691121502 Question Type : MCQ Option Shuffling : Yes Display Question Number : Yes Is Question Mandatory : No Single Line Question Option : No Option Orientation : Vertical

Which of the following statement(s) is/are **true** ?

- A. If two orbitals have the same value of $(n + l)$, the orbital with lower value of n will have lower energy.
- B. Energies of the orbitals in the same subshell increase with increase in atomic number.
- C. The size of $2p_x$ orbital is less than the size of $3p_x$ orbital.
- D. Among $5f$, $6s$, $4d$, $5p$ and $5d$ orbitals, none of the orbitals have 2 radial nodes.

Choose the **correct** answer from the options given below :

Options :

6911211705. A, B and C only

6911211706. A and C only

6911211707. C and D only

6911211708. A only

Question Number : 53 Question Id : 691121503 Question Type : MCQ Option Shuffling : Yes Display Question Number : Yes Is Question Mandatory : No Single Line Question Option : No Option Orientation : Vertical

The covalent radii of atoms A and B are r_A and r_B , respectively. The covalent bond length and total length of AB molecule are respectively

Options :

6911211709. $(r_A + r_B)$, $2(r_A + r_B)$

6911211710. $\frac{1}{2}(r_A + r_B)$, $(r_A + r_B)$

6911211711. $(r_A + r_B)$, $(r_A + r_B)$

6911211712. $2(r_A + r_B)$, $\frac{1}{2}(r_A + r_B)$

Question Number : 54 Question Id : 691121504 Question Type : MCQ Option Shuffling : Yes Display Question Number : Yes Is Question Mandatory : No Single Line Question Option : No Option Orientation : Vertical

Consider the following data for the reaction

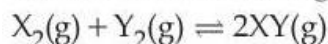

at 600 K. The $\Delta_r G^\ominus$ (in kJ mol^{-1}) for the reaction is :

| Compound | $\Delta_f H_{600\text{K}}^\ominus$ (kJ mol^{-1}) | $S_{600\text{K}}^\ominus$ ($\text{J mol}^{-1} \text{K}^{-1}$) |
|----------|---|---|
| XY(g) | 42 | 200 |
| $X_2(g)$ | 8 | 140 |
| $Y_2(g)$ | 80 | 250 |

Options :

6911211713. - 21000

6911211714. - 10

6911211715. - 1000

6911211716. - 9.012

Question Number : 55 Question Id : 691121505 Question Type : MCQ Option Shuffling : Yes Display Question Number : Yes Is Question Mandatory : No Single Line Question Option : No Option Orientation : Vertical

The correct order of molar heat capacities measured at 298 K and 1 bar is :

Options :

6911211717. Copper(s) > Bromine(l) > Helium(g)

6911211718. Bromine(l) > Copper(s) > Helium(g)

6911211719. Helium(g) > Bromine(l) > Copper(s)

6911211720. Helium(g) > Bromine(l) = Copper(s)

Question Number : 56 Question Id : 691121506 Question Type : MCQ Option Shuffling : Yes Display Question Number : Yes Is Question Mandatory : No Single Line Question Option : No Option Orientation : Vertical

The reaction $A(g) \rightleftharpoons B(g) + C(g)$ was initiated with the amount 'a' of A(g). At equilibrium it is found that the amount of A(g) remaining is (a - x) at a total pressure of p.

The equilibrium constant K_p of the reaction can be calculated from the expression :

Options :

6911211721. $\frac{x^2}{a^2 + x^2} \times p$

6911211722. $\frac{x^2}{a^2-x^2} \times p$

6911211723. $\frac{a+x^2}{x^2} \times p$

6911211724. $\frac{a^2-x^2}{x^2} \times p$

Question Number : 57 Question Id : 691121507 Question Type : MCQ Option Shuffling : Yes Display Question Number : Yes Is Question Mandatory : No Single Line Question Option : No Option Orientation : Vertical

One half cell in a voltaic cell is constructed by dipping silver rod in AgNO_3 solution of unknown concentration, other half cell is Zn rod dipped in 1 molar solution of ZnSO_4 .

A voltage of 1.60 V is measured at 298 K for this cell. What is the concentration of Ag^+ ions used in terms of $\log x$ ($x = [\text{Ag}^+]$) ?

$$E_{\text{Zn}^{2+}/\text{Zn}}^\ominus = -0.76\text{V}, \quad E_{\text{Ag}^+/\text{Ag}}^\ominus = +0.80\text{V}, \quad \frac{2.303RT}{F} = 0.059\text{V}$$

Options :

6911211725. $\frac{2}{3.9}$

6911211726. $\frac{4}{5.9}$

6911211727. $\frac{2.9}{2}$

6911211728. $\frac{5.9}{4}$

Question Number : 58 Question Id : 691121508 Question Type : MCQ Option Shuffling : Yes Display Question Number : Yes Is Question Mandatory : No Single Line Question Option : No Option Orientation : Vertical

Given below are two statements :

Statement I : The number of pairs among $[\text{Al}_2\text{O}_3, \text{Cr}_2\text{O}_3]$, $[\text{Cl}_2\text{O}_7, \text{Mn}_2\text{O}_7]$, $[\text{Na}_2\text{O}, \text{V}_2\text{O}_3]$ and $[\text{CO}, \text{N}_2\text{O}]$ that contain oxides of same nature (acidic, basic, neutral or amphoteric) is 4.

Statement II : Among Na_2O , Al_2O_3 , CO and Cl_2O_7 , the most basic and acidic oxides are Na_2O and Cl_2O_7 , respectively.

In the light of the above statements, choose the **correct** answer from the options given below :

Options :

6911211729. Both **Statement I** and **Statement II** are true

6911211730. Both **Statement I** and **Statement II** are false

6911211731. **Statement I** is true but **Statement II** is false

6911211732. **Statement I** is false but **Statement II** is true

Question Number : 59 Question Id : 691121509 Question Type : MCQ Option Shuffling : Yes Display Question Number : Yes Is Question Mandatory : No Single Line Question Option : No Option Orientation : Vertical

Given below are two statements :

Statement I : Aluminium upon reaction with NaOH forms $[\text{Al}(\text{OH})_6]^{3-}$ ion.

Statement II : The geometry of ICl_4^- , ClO_3^- and IBr_2^- is square planar, pyramidal and linear respectively.

In the light of the above statements, choose the **correct** answer from the options given below :

Options :

6911211733. Both **Statement I** and **Statement II** are true

6911211734. Both **Statement I** and **Statement II** are false

6911211735. **Statement I** is true but **Statement II** is false

6911211736. **Statement I** is false but **Statement II** is true

Question Number : 60 Question Id : 691121510 Question Type : MCQ Option Shuffling : Yes Display Question Number : Yes Is Question Mandatory : No Single Line Question Option : No Option Orientation : Vertical

Given below are two statements :

Statement I : Presence of large number of unpaired electrons in transition metal atoms results in higher enthalpies of their atomisation.

Statement II : $d_{xy} = d_{xz} = d_{yz} < d_{x^2-y^2} = d_{z^2}$ and $d_{x^2-y^2} = d_{z^2} < d_{xy} = d_{xz} = d_{yz}$ are the d-orbital splittings in $[\text{Fe}(\text{H}_2\text{O})_6]^{3+}$ and $[\text{Ni}(\text{Cl})_4]^{2-}$ complex ions respectively.

In the light of the above statements, choose the **correct** answer from the options given below :

Options :

6911211737. Both **Statement I** and **Statement II** are correct

6911211738. Both **Statement I** and **Statement II** are incorrect

6911211739. **Statement I** is correct but **Statement II** is incorrect

6911211740. **Statement I** is incorrect but **Statement II** is correct

Question Number : 61 Question Id : 691121511 Question Type : MCQ Option Shuffling : Yes Display Question Number : Yes Is Question Mandatory : No Single Line Question Option : No Option Orientation : Vertical

Identify the **correct** statements from the following

- A. $[\text{Fe}(\text{C}_2\text{O}_4)_3]^{3-}$ is the most stable complex among $[\text{Fe}(\text{OH})_6]^{3-}$, $[\text{Fe}(\text{C}_2\text{O}_4)_3]^{3-}$ and $[\text{Fe}(\text{SCN})_6]^{3-}$
- B. The stability of $[\text{Cu}(\text{NH}_3)_4]^{2+}$ is greater than that of $[\text{Cu}(\text{en})_2]^{2+}$
- C. The hybridization of Fe in $\text{K}_4[\text{Fe}(\text{CN})_6]$ is d^2sp^3
- D. $[\text{Fe}(\text{NO}_2)_3\text{Cl}_3]^{3-}$ exhibits linkage isomerism
- E. NO_2^- and SCN^- ligands are NOT ambidentate ligands

Choose the **correct** answer from the options given below :

Options :

6911211741. A, B, C, D and E

6911211742. B, C and D only

6911211743. A, C and D only

6911211744. A, C and E only

Question Number : 62 Question Id : 691121512 Question Type : MCQ Option Shuffling : Yes Display Question Number : Yes Is Question Mandatory : No Single Line Question Option : No Option Orientation : Vertical

Match List - I with List - II.

List - I

Purification technique

- A. Simple distillation
- B. Fractional distillation
- C. Steam distillation
- D. Distillation under reduced pressure

List - II

Used to separate

- I. Steam volatile compound
- II. Two liquids with large difference in boiling points
- III. Liquid decomposing at its boiling point
- IV. Two liquids with close boiling points

Choose the **correct** answer from the options given below :

Options :

6911211745. A-II, B-III, C-I, D-IV

6911211746. A-II, B-IV, C-I, D-III

6911211747. A-II, B-IV, C-III, D-I

6911211748. A-IV, B-III, C-II, D-I

Question Number : 63 Question Id : 691121513 Question Type : MCQ Option Shuffling : Yes Display Question Number : Yes Is Question Mandatory : No Single Line Question Option : No Option Orientation : Vertical

IUPAC name of the some alkenes are given below.

Find out the correct stability order.

- A. 2-Methylbut-2-ene
- B. *cis*-But-2-ene
- C. 2, 3-Dimethylbut-2-ene
- D. Prop-1-ene

Choose the **correct** answer from the options given below :

Options :

6911211749. C > A > B > D

6911211750. C > A > D > B

6911211751. B > D > A > C

6911211752. A > B > C > D

Question Number : 64 Question Id : 691121514 Question Type : MCQ Option Shuffling : Yes Display Question Number : Yes Is Question Mandatory : No Single Line Question Option : No Option Orientation : Vertical

Identify the correct IUPAC name of hydrocarbon (x) containing three primary carbon atoms and with molar mass 72 g mol^{-1} .

Options :

6911211753. 1, 1 - Dimethylcyclopropane

6911211754. 2, 2 - Dimethylpropane

6911211755. 2 - Methylbutane

6911211756. n-pentane

Question Number : 65 Question Id : 691121515 Question Type : MCQ Option Shuffling : Yes Display Question Number : Yes Is Question Mandatory : No Single Line Question Option : No Option Orientation : Vertical

Complete the following reaction sequence and give the name of major product 'P'.

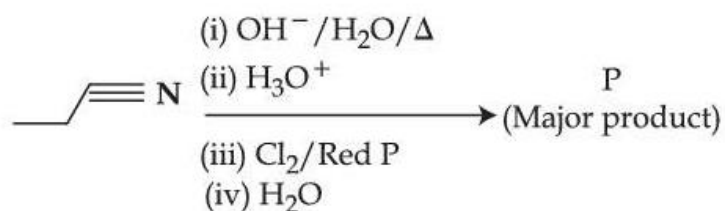

Options :

6911211757. 2-Chloropropanoic acid

6911211758. 3-Chloropropanoic acid

6911211759. 1-Chloropropane

6911211760. 2-Chloropropane

Question Number : 66 Question Id : 691121516 Question Type : MCQ Option Shuffling : Yes Display Question Number : Yes Is Question Mandatory : No Single Line Question Option : No Option Orientation : Vertical

Given below are two statements :

Statement I : The condensation reaction between $\text{CH}_3 - \text{CH} = \text{O}$ and $\text{H}_2\text{N} - \text{N}(\text{H}) - \text{C}(=\text{O}) - \text{NH}_2$ under optimum pH will produce $\text{CH}_3 - \text{CH} = \text{N} - \text{C}(=\text{O}) - \text{N}(\text{H}) - \text{NH}_2$

Statement II : The molecule, $\text{Ph} - \text{CH}(\text{O}-\text{H})(\text{O}-\text{CH}_3)$ will generate $\text{Ph} - \text{CH} = \text{O}$ in the presence of dilute acid.

In the light of the above statements, choose the **correct** answer from the options given below :

Options :

6911211761. Both **Statement I** and **Statement II** are true

6911211762. Both **Statement I** and **Statement II** are false

6911211763. **Statement I** is true but **Statement II** is false

6911211764. **Statement I** is false but **Statement II** is true

Question Number : 67 Question Id : 691121517 Question Type : MCQ Option Shuffling : Yes Display Question Number : Yes Is Question Mandatory : No Single Line Question Option : No Option Orientation : Vertical

Given below are two statements :

Statement I : Heating benzamide with bromine in an ethanolic solution of sodium hydroxide will give benzylamine.

Statement II : Nitration of aniline with $\text{HNO}_3/\text{H}_2\text{SO}_4$ at 288 K produces *m*-nitroaniline in higher amount than *o*-nitroaniline (pH adjusted).

In the light of the above statements, choose the **correct** answer from the options given below :

Options :

6911211765. Both **Statement I** and **Statement II** are true

6911211766. Both **Statement I** and **Statement II** are false

6911211767. **Statement I** is true but **Statement II** is false

6911211768. **Statement I** is false but **Statement II** is true

Question Number : 68 Question Id : 691121518 Question Type : MCQ Option Shuffling : Yes Display Question Number : Yes Is Question Mandatory : No Single Line Question Option : No Option Orientation : Vertical

Identify the **incorrect** statement about tertiary structure of proteins.

Options :

6911211769. They can be fibrous or globular in structure.

6911211770.

The main forces that stabilize the structure are hydrogen bonding, disulphide links, van der Waals and electrostatic forces of attraction.

6911211771. The structure remains intact when exposed to pH changes.

6911211772.

A linear polypeptide chain will convert to a secondary structure and then further folding of the secondary structure will convert to tertiary structure.

Question Number : 69 Question Id : 691121519 Question Type : MCQ Option Shuffling : Yes Display Question Number : Yes Is Question Mandatory : No Single Line Question Option : No Option Orientation : Vertical

Given below are two statements :

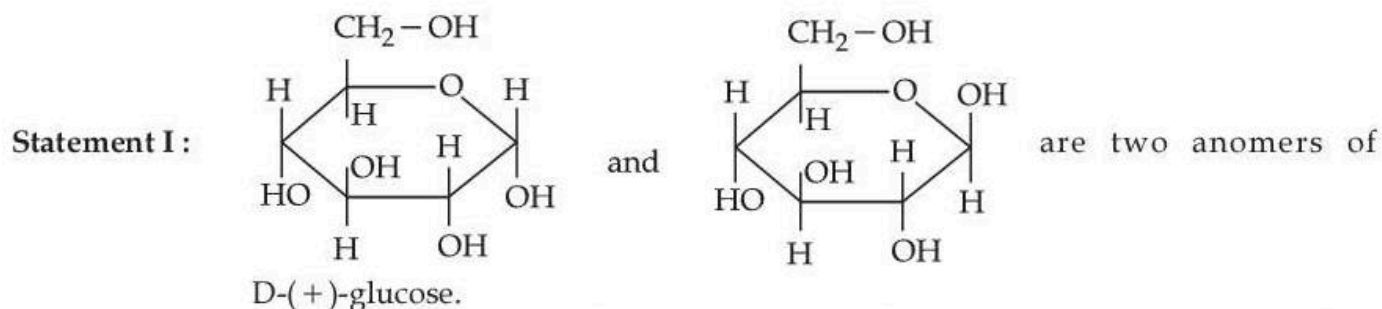

Statement II : The open chain forms of D-glucose and D-fructose contain three similar chiral carbons at C_3 , C_4 and C_5 .

In the light of the above statements, choose the **correct** answer from the options given below :

Options :

6911211773. Both **Statement I** and **Statement II** are true

6911211774. Both **Statement I** and **Statement II** are false

6911211775. **Statement I** is true but **Statement II** is false

6911211776. **Statement I** is false but **Statement II** is true

Question Number : 70 Question Id : 691121520 Question Type : MCQ Option Shuffling : Yes Display Question Number : Yes Is Question Mandatory : No Single Line Question Option : No Option Orientation : Vertical

A paper dipped in a dil. H_2SO_4 solution of 'X' upon treatment with SO_2 gas turns into green. The compound 'X' is :

Options :

6911211777. KI-starch

6911211778. KMnO_4

6911211779. $\text{Pb}(\text{CH}_3\text{COO})_2$

6911211780. $\text{K}_2\text{Cr}_2\text{O}_7$

Chemistry Section B

| | |
|---------------------------------------|-----------|
| Section Id : | 69112142 |
| Section Number : | 6 |
| Section type : | Online |
| Mandatory or Optional : | Mandatory |
| Number of Questions : | 5 |
| Number of Questions to be attempted : | 5 |
| Section Marks : | 20 |
| Maximum Instruction Time : | 0 |
| Sub-Section Number : | 1 |
| Sub-Section Id : | 69112142 |
| Question Shuffling Allowed : | Yes |
| Is Section Default? : | No |

Question Number : 71 Question Id : 691121521 Question Type : SA Display Question Number : Yes Keyboard Layout : Inscript

The total number of unpaired electrons present in the d^3 , d^4 (low spin) d^5 (high spin), d^6 (high spin) and d^7 (low spin) octahedral complex systems is _____.

Response Type : Numeric

Evaluation Required For SA : Yes

Show Word Count : Yes

Answers Type : Equal

Text Areas : PlainText

Possible Answers :

1

Question Number : 72 Question Id : 691121522 Question Type : SA Display Question Number : Yes Keyboard Layout : Inscript

RMgI when treated with ice cold water liberated a gas which occupied $1.4 \text{ dm}^3/\text{g}$ at STP. The gas produced is further reacted with iodine in presence of HIO_3 to give compound (X). Compound (X) in presence of Na and dry ether produced compound (Y). Molar mass of compound (Y) is _____ g mol^{-1} . (Nearest integer)

Response Type : Numeric

Evaluation Required For SA : Yes

Show Word Count : Yes

Answers Type : Equal

Text Areas : PlainText

Possible Answers :

1

Question Number : 73 Question Id : 691121523 Question Type : SA Display Question Number : Yes Keyboard Layout : Inscript

20 g hemoglobin in a 1 L aqueous solution (A) at 300 K is separated from pure water by semi permeable membrane. At equilibrium the height of solution in a tube dipped in a solution (A) is found to be 80.0 mm higher than the tube dipped in water.

The molar mass of hemoglobin is _____ kg mol^{-1} . (Nearest integer)

(Given : $g = 10 \text{ m s}^{-2}$, $R = 8.3 \text{ kPa dm}^3 \text{ K}^{-1} \text{ mol}^{-1}$, density of solution = 1000 kg m^{-3})

Response Type : Numeric

Evaluation Required For SA : Yes

Show Word Count : Yes

Answers Type : Equal

Text Areas : PlainText

Possible Answers :

1

Question Number : 74 Question Id : 691121524 Question Type : SA Display Question Number : Yes Keyboard Layout : Inscript

At 298 K, the molar conductivity of $x\%$ (w/w) MX solution (aqueous) is $123.5 \text{ S cm}^2 \text{ mol}^{-1}$. The conductance of same solution is $1.9 \times 10^{-3} \text{ S}$. The value of x is _____ $\times 10^{-2}$.

(Given : cell constant = 1.3 cm^{-1} ; molar mass of MX is 75 g mol^{-1} , density of aqueous solution of MX at 298 K is 1.0 g mL^{-1})

Response Type : Numeric

Evaluation Required For SA : Yes

Show Word Count : Yes

Answers Type : Equal

Text Areas : PlainText

Possible Answers :

1

Question Number : 75 Question Id : 691121525 Question Type : SA Display Question Number : Yes Keyboard Layout : Inscript

For a reaction $A \rightarrow P$ at T K, the half life ($t_{1/2}$) is plotted as a function of initial concentration $[A]_0$ of A as given below.

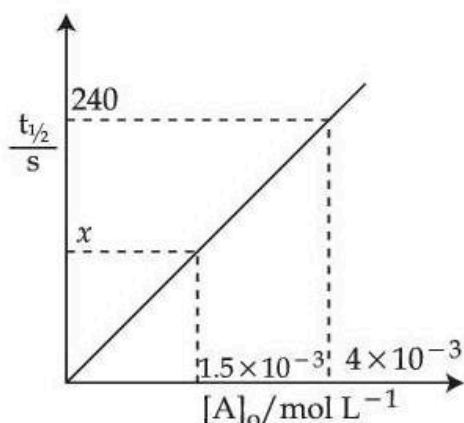

The value of x in the given figure is _____ s (Nearest integer)

Response Type : Numeric

Evaluation Required For SA : Yes

Show Word Count : Yes

Answers Type : Equal

Text Areas : PlainText

Possible Answers :

1